



SUTHONG
— MACHINERY —

HIGH TECHNOLOGY CENTER



**MACHINERY FOR
METALWORKING INDUSTRY**

COMPANY PROFILE



บริษัท สุทอง แมชชีนเนอรี จำกัด

ก่อตั้งเมื่อปี ค.ศ. 1990 เป็นตัวแทนนำเข้าสินค้าประเภทเครื่องจักร และอุปกรณ์สนับสนุนในด้านการผลิตชิ้นงานโลหะหลากหลายประเภท จากต่างประเทศที่ได้รับการตรวจสอบและผ่านการรับประกันคุณภาพ ในระดับสากล ตลอดระยะเวลาในการดำเนินงาน เรามุ่งมั่นที่จะดำเนินธุรกิจเพื่อเป็นพวุนระกอบการที่ดี โดยยึดมั่นในวิสัยทัศน์ที่ว่า

Suthong Machinery Co.,Ltd.

was incorporated in 1990. We carry on business of importation and dealership of machinery and equipment used in a variety of metalworking industries which certified by ISO, pass the highest standard of inspection and quality assurance. Up to present, we have enjoyed our achievement and prosperity. We adhere to the vision of

“ร่วมทำครึ่งเดียว สร้างพันธมิตรตลอดชีพ”

“The lifelong partnership starts once dealing with us”

มอบความซื่อสัตย์และมีความรับผิดชอบอย่างสูงต่อลูกค้า ทั้งก่อน และหลังการขาย นอกจากนี้ บริษัท สุทอง แมชชีนเนอรี จำกัด ยังได้ ส่งทีมช่างไปฝึกอบรมด้านเทคนิคยังต่างประเทศในด้านเครื่องจักร ทั้งการติดตั้ง การซ่อมบำรุง และการให้บริการต่างๆ อย่างสม่ำเสมอ เพื่อพัฒนาประสิทธิภาพ และให้ค่าบริการที่เป็นประโยชน์สูงสุดต่อลูกค้าจนทำให้ธุรกิจได้ประสบความสำเร็จและเจริญก้าวหน้าเป็นลำดับ จนเป็นที่ยอมรับของโรงงานผู้ผลิตชิ้นส่วนโลหะชั้นนำทั่วประเทศ จนถึงปัจจุบัน

We maintain the highest integrity and take responsibility for our clients both before and after sales. In addition, we guarantee our after-sales services in all aspects including machine delivery, maintenance and user training. We presently have experienced and competent technical officers always available for service to provide supports and technical advices. And we constantly send our people training abroad for continuous skill improvement. Thus far we are so proud to present that, we render the excellent after-sales service to our clients in almost every category of industrial sectors.



นโยบายบริษัท

เรามีวิสัยทัศน์ที่ต้องการพัฒนาอุตสาหกรรมการผลิตของไทยในด้านอุตสาหกรรมชิ้นส่วนโลหะสำหรับยานยนต์ อากาศยาน อะไหล่เครื่องจักร และอื่นๆ เพื่อช่วยผลักดันและสนับสนุนการผลิตและส่งออกของประเทศไทยให้อยู่ในระดับแนวหน้า

นโยบายคุณภาพ

เรามุ่งมั่นที่จะเป็นบริษัทชั้นนำของประเทศ ในการจำหน่ายเครื่องจักรที่ทันสมัย มีคุณภาพ และให้ความสำคัญเป็นอย่างยิ่งกับการบริการหลังการขาย ส่งมอบสินค้าตรงเวลาเพื่อลูกค้าพึงพอใจสูงสุด และพัฒนาบุคลากรและกระบวนการการทำงานอย่างต่อเนื่อง

นโยบายบุคลากร

จนถึงปัจจุบัน บริษัทมีการพัฒนาพนักงานให้มีจิตสำนึกด้านการให้บริการที่ดีแก่ลูกค้า มีความรู้ในสินค้าเป็นอย่างดี มีคุณธรรม นอกจากนี้ยังส่งเสริมวิศวกรและพนักงานไปศึกษาและอบรมในต่างประเทศอย่างต่อเนื่องเป็นประจำทุกปี เพื่อพัฒนาความรู้แก่พนักงานที่เกี่ยวข้องทุกคน



SERVICE



การติดตั้ง

บริษัทเราให้บริการบริการติดตั้ง โดยทีมช่างที่มีความชำนาญสูง และเชี่ยวชาญเรื่องเครื่องจักรโดยเฉพาะ อย่างมีมาตรฐาน

การฝึกอบรม (การทำงาน เครื่องจักร และซอฟต์แวร์)









เราให้การฝึกอบรมหลังการติดตั้งโดยทีมผู้เชี่ยวชาญ รวมถึงเทคนิคต่างๆ ในการควบคุมการทำงานเครื่องจักรและซอฟต์แวร์ เพื่อให้ผู้ใช้งานสามารถใช้งานเครื่องจักรได้อย่างมีประสิทธิภาพ

การซ่อมบำรุง







เราให้บริการบริการซ่อมบำรุงแก่ลูกค้าหลังการขาย ด้วยทีมช่างที่มีประสบการณ์สามารถวิเคราะห์ปัญหาได้อย่างรวดเร็วและแม่นยำ เราให้การติดต่อแก่ลูกค้าอย่างสม่ำเสมอ เพื่อให้ลูกค้ามั่นใจได้ว่าเครื่องจักรที่ใช้งาน ทำงานได้สมบูรณ์ต่อเนื่องและมีประสิทธิภาพ



CONTENT - สารบัญ

Page	Brand	Machine Type
06		FHBS Laser Cutting Machine
08		POLY GIM CNC Lathe Machine (Swiss Type)
14		YIPC CNC Lathe Machine
16		ARES SEIKI CNC Drilling & Tapping Machine
24		PRATIC CNC Long Travel Machining Center
28		MILLSTAR CNC Machining Machine
32		SIGMA CNC Double Column Machining Center
34		SUN MASTER Lathe Machine
38		KENT Grinding Machine



Page	Brand	Machine Type
42		TAILIFT Radial Drill Machine
44		KANTAI Circular Sawing Machine
46	GENERAL	GENERAL Drilling Machine / Tapping Machine
48		PBM Milling Machine
50		JING DUANN Punching Machine
51		KCM Cutting / Punching Machine
52		KAI HUNG Combination Machine Center
54		YAGA Linear Scale

HDE Series Full Cover & Shuttle Table Laser Cutting Machine



KE SERIES

HDE SERIES

MACHINE SPECIFICATIONS

LASER POWER	WORKING AREA(LxW)	STROKE(X/Y/Z AXIS)	X/Y AXIS REPOSITIONING ACCURACY
1000W-4000W	3000x1500mm	1500mm/3050mm/100mm	-0.02
MAX.MOVING SPEED	MAX.ACC.SPEED	OVERALL DIMENSIONS (LxWxH)	MACHINE WEIGHT
120m/min	1.2G	8910x2260x2200mm	≈5858kg

LASER POWER	WORKING AREA(LxW)	STROKE(X/Y/Z AXIS)	X/Y AXIS REPOSITIONING ACCURACY
1000W-3000W	3000x1500mm	1520mm/3050mm/100mm	-0.05
MAX.MOVING SPEED	MAX.ACC.SPEED	OVERALL DIMENSIONS(LxWxH)	MACHINE WEIGHT
60m/min	0.6G	4535x2235x1790mm	≈1800kg

LASER CUTTING HEAD

Auto Focus

Applicable to multiple focal lengths, automatically adjusts focal position in cutting process by different sheet thickness.

Free Your Hands

Focal length is controlled by operating system, which effectively avoids errors or faults caused by manual operation.

Simple and Fast

When technician changes different metal sheet, Auto focus laser head can automatically read system storage parameters, which make the cutting process less gas, less electricity, lower cost, high efficiency.

Accurate

By setting perforation focal length and cutting focal length respectively, the cutting is more accurate.

Tube Laser Cutting Machine

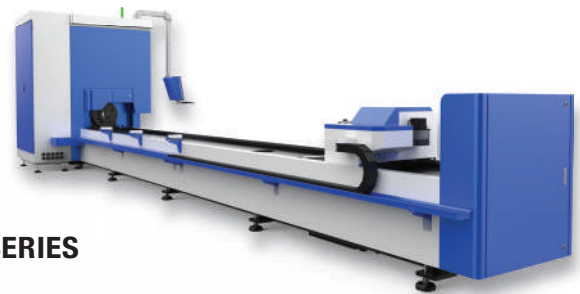

K SERIES

MACHINE SPECIFICATIONS

Feature/Model	V Series				G Series		K SERIES	
	V35X	V35XL	V38XL	V50XL-U	G22	G22X	K12	K12X
Laser Power	3000W - 6000W	3000W - 6000W	3000W - 12000W	3000W - 12000W	1500W x 6000W	1500W x 6000W	1000W x 3000W	1000W - 3000W
Pipe Processing Range	φ20-350mm	φ20-350mm	Max. diamter of round pipe:φ380mm	φ50-500mm	10-220mm / 10-150mm	10-220mm / 10-150mm	φ10-85mm / 10-85mm	φ10-120mm / 10-85mm
	20-250mm	20-250mm	Max. square tube:270mm-270mm	50-350mm		U-Steel 5#-16# / I-Beam 10#-16# / Angle Iron 30-100		Channel Steel 5#-6.5# / Angle Iron 30-60
	U-Steel 5#-32#	U-Steel 5#-32#	Max. of channel steel: 36#	U-Steel 5#-40#	-	-	-	-
	I-Beam 10#-25#	I-Beam 10#-25#	Max. of I-beam:32#	I-Beam 10#-40#	-	-	-	-
	Angle Iron 30-100	Angle Iron 30-100	Max. of Angle iron:12#	Angle Iron 250-250	-	-	-	-
Pipe Processing Length	6500mm	10000mm	12000mm	12000mm	6500mm	6500mm	6500mm	6500mm
Max Single Tube Loading Weight	400KG	400KG	1000KG	1500KG	170kg	205kg	75kg	85kg
Max.Acc.Speed	0.6G	0.6G	0.5G	0.4G	0.8G	1.0G	0.8G	1.0G
Max. Chuck Speed	80r/min	80r/min	50r/min	40r/min	100r/min	107r/min	100r/min	140r/min
Tail Length	350mm	350mm	350mm	0	130mm	130mm	130mm	130mm
Overall Dimension(LxWxH) Without Feeding and Receiving Device	10250x2700 x2700mm	12000x2700 x2700mm	15500x2700 x3250mm	30000x5000 x3250mm	9300x2700 x2400mm	9680x2700 x2620mm	8910x1550 x2100mm	9380x2700 x2600mm
Machine Weight Without Feeding and Receiving Device	≈5600kg	≈7500kg	≈11000kg	≈23210kg	≈2958kg	≈4900kg	≈2200kg	≈4100kg

Laser Cutting Machine

HBDE Series Blue



HBDE Series Red

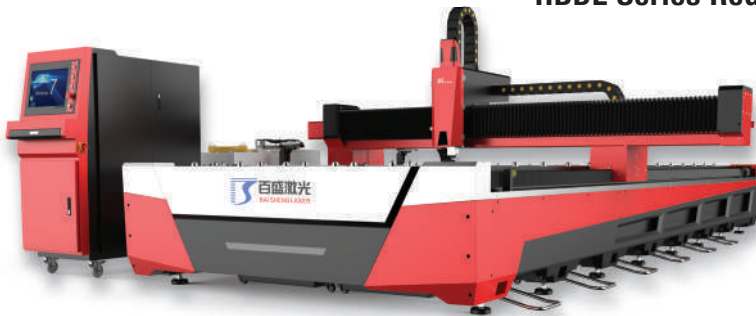

MACHINE SPECIFICATIONS

Feature/Model	BE SERIES				HBDE Series Blue			HBDE Series Red		
	F3015BE	F4020BE	F6015BE	F6020BE	F3015HBDE	F4020HBDE	F6020HBDE	F3015HBDE	F4020HBDE	F6020HBDE
Laser Power	1000W-4000W	1000W-6000W	1000W-6000W	1000W-6000W	1000W-6000W	1000W-15000W	1000W-15000W	1000W-6000W	1000W-15000W	1000W-15000W
Working Area(LxW)	3000x1500mm	4000x2000mm	6000x1500mm	6000x2000mm	3000x1500mm	4000x2000mm	6000x2000mm	3000x1500mm	4000x2000mm	6000x2000mm
stroke (x/y/z Axis)	2290mm/3050mm /200mm	2780mm/4050mm /200mm	2290mm/6050mm /200mm	2780mm/6050mm /200mm	2450mm/3050mm /200mm	2950mm/4050mm /300mm	3050mm/6050mm /300mm	2450mm/3050mm /200mm	2950mm/4050mm /300mm	3050mm/6050mm /300mm
X/Y Reposition Accuracy	±0.02mm	±0.02mm	±0.02mm	±0.02mm	±0.02mm/m	±0.02mm/m	±0.02mm/m	±0.02mm/m	±0.02mm/m	±0.02mm/m
Max.Moving Speed	100m/min	100m/min	100m/min	100m/min	100m/min	100m/min	100m/min	100m/min	100m/min	100m/min
Max.Acc. Speed	1.0G	1.0G	1.0G	1.0G	1.0G	1.0G	1.0G	1.0G	1.0G	0.8G
Overall Dimension(LxWxH)	4600x3500 x2200mm	6000x4000 x2200mm	8300x3520 x2200mm	8300x4000 x2200mm	9850x4000 x2300mm	12330x4500 x2300mm	16352x4900 x2700mm	9850x4000 x2300mm	12330x4500 x2300mm	16352x4900 x2700mm
Machine Weight	≈2800kg	≈4400kg	≈5100kg	≈6100kg	≈8000kg	≈10500kg	≈16500kg	≈7000kg	≈9200kg	≈16000kg

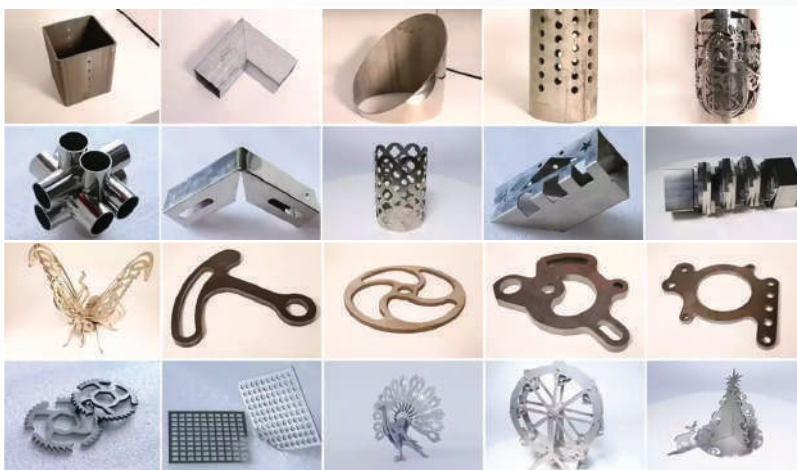

Swiss Type CNC Auto Lathe

**SIMPLICITY Precision-
Speed
DURABILITY Stability**



DIAMOND 12/12CS/16/16CS



DIAMOND 20/20B/20CS/20CSB

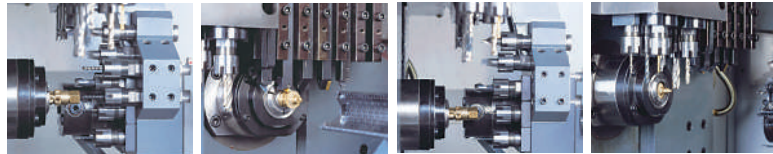

4 I.D. Stationary tools

6 O.D. Turning tools

3 Front working driven tools : front eccentric drilling/tapping

6 Cross working driven tools : cross slide drilling/milling/tapping

MACHINE SPECIFICATIONS

Items	DIAMOND 12	DIAMOND 12CS	DIAMOND 16	DIAMOND 16CS	DIAMOND 20	DIAMOND 20B	DIAMOND 20CS	DIAMOND 20CSB
Working Range	Max. Machining Dia.	Ø12.7 mm	Ø12.7 mm	Ø16.5 mm	Ø16.5 mm	Ø20 mm	Ø20 mm	Ø20 mm
	Max. Machining Length Per Chucking	145 mm	145 mm	145 mm	145 mm	250 mm	250 mm	250 mm
	Max. Drilling Dia.	Ø7 mm	Ø7 mm	Ø10 mm	Ø10 mm	14 mm	14 mm	14 mm
	Max. Tapping Dia.	M6	M6	M8	M8	M10	M10	M10
O.D. Tooling	Number of Tools	6	6	6	6	6	6	6
	Dimension	□10×10×100	□10×10×100	□10×10×100	□10×10×100	□12×12×100	□12×12×100	□12×12×100
I.D. Tooling	Number of Tools	4	4	4	4	4	4	4
	Dimension	7 mm (ER11)	7 mm (ER11)	10 mm (ER16)	10 mm (ER16)	10 mm (ER16)	10 mm (ER16)	10 mm (ER16)
Cross Working Driven Tooling	Number of Tools	-	4	-	4	-	-	6
	Dimension	-	7 mm (ER11)	-	10 mm (ER16)	-	-	10 mm (ER16)
	Cross Spindle Speed	-	200~3000 rpm	-	200~3000 rpm	-	-	200~6000 r.p.m.
Front Working Driven Tooling	Number of Tools	-	3	-	3	-	-	3
	Dimension	-	7mm (ER11)	-	10 mm (ER16)	-	-	10 mm (ER16)
	Spindle Speed	-	200~3000 rpm	-	200~3000 rpm	-	-	6000 r.p.m.
Back I.D. Tooling	Number of Tools	-	-	-	-	-	-	4
	Dimension	-	-	-	-	-	10 mm (ER16)	-
Back Working Driven Tooling	Number of Tools	-	-	-	-	-	-	-
	Dimension	-	-	-	-	-	-	7 mm (ER11)
	Spindle Speed	-	-	-	-	-	-	6000 r.p.m.
Spindle	Bore of Spindle	-	-	-	-	Ø21 mm	Ø21 mm	Ø21 mm
	Spindle Speed	-	-	-	-	200-10000 r.p.m.	200-10000 r.p.m.	200-10000 r.p.m.
Back Spindle	Back Spindle Hole Dia.	-	-	-	-	-	Ø21 mm	-
	Back Spindle Speed	-	-	-	-	-	7500 r.p.m.	-
	Max. Length for Front Ejection	-	-	-	-	-	80 mm	-
Rapid Speed	Rapid Speed	-	-	-	-	18 M	18 M	18 M
Main Spindle	Spindle hole dia.	Ø13 mm	Ø13 mm	Ø17 mm	Ø17 mm	-	-	-
	Spindle speed	200-8,000 r.p.m.	200-8,000 r.p.m.	200-8,000 r.p.m.	200-8,000 r.p.m.	-	-	-
	Spindle indexing angle	-	C axis (opt. CS axis 0.01° indexing)	-	C axis (opt. CS axis 0.01° indexing)	-	-	-
Rapid Traverse	X1, Y1, Z1 axes	30 M	30 M	30 M	30 M	-	-	-
Motors	Main Spindle Motor	2.2 kW	2.2 kW	2.2 kW	2.2 kW	3.7 kw	3.7 kw	3.7 kw
	Back Spindle Motor	-	-	-	-	-	1.5 kw	-
	X1, Y1, Z1 Axis Motor	1 kW	1 kW	1 kW	1 kW	0.5 kw	0.5 kw	0.5 kw
	Z2 Axis Motor	-	-	-	-	-	0.5 kw	-
	Coolant Pump	1/4 HP	1/4 HP	1/4 HP	1/4 HP	0.18 kw	0.18 kw	0.18 kw
	Lubrication	4 w	4 w	4 w	4 w	4 w	4 w	4 w
	Cross Spindle	-	-	-	-	-	-	0.75 kw
Machine Dimensions	Center Height	1050 mm	1050 mm	1050 mm	1050 mm	960 mm	960 mm	960 mm
	Weight	1188 kg	1208 kg	1220 kg	1240 kg	2150 kg	2650 kg	2168 kg
	Machine Dimension	1200x900x1750 mm	1200x900x1750 mm	1200x900x1750 mm	1200x900x1750 mm	1588x988x1568 mm	1788x988x1568 mm	1588x988x1568 mm
Air Pressure	Air Pressure	5 kg/cm	5 kg/cm	5 kg/cm	5 kg/cm	5 kg/cm	5 kg/cm	5 kg/cm
	Air Supply	10 L/min	10 L/min	10 L/min	10 L/min	10 L/min	10 L/min	10 L/min



DIAMOND 32 / 32B / 32CS / 32CSB

MACHINE SPECIFICATIONS

Items	DIAMOND 32	DIAMOND 32B	DIAMOND 32CS	DIAMOND 32CSB
Working Range	Max. Machining Dia.	Ø33 mm	Ø33 mm	Ø33 mm
	Max. Machining Length Per Chucking	250 mm	250 mm	250 mm
	Max. Drilling Dia.	26 mm	26 mm	26 mm
	Max. Tapping Dia.	M12	M12	M12
	Number of Tools	6	6	5
O.D. Tooling	Dimension	□16 ×16 ×120	□16 ×16 ×120	□16 ×16 ×120
	Number of Tools	4	4	4
I.D. Tooling	Dimension	13 mm (ER20)	13 mm (ER20)	13mm (ER20)
	Number of Tools	-	-	6
Cross Working Driven Tooling	Dimension	-	-	13mm (ER20)
	Cross Spindle Speed	-	-	200-6000 r.p.m.
	Number of Tools	-	-	3
Front Working Driven Tooling	Dimension	-	-	13 mm (ER20)
	Spindle Speed	-	-	6000 r.p.m.
	Number of Tools	-	4	-
Back I.D. Tooling	Dimension	-	13 mm (ER20)	-
	Number of Tools	-	-	3
Back Working Driven Tooling	Dimension	-	-	10 mm (ER16)
	Spindle Speed	-	-	6000 r.p.m.
	Bore of Spindle	Ø36 mm	Ø36 mm	Ø36 mm
Spindle	Spindle Speed	200- 8000 r.p.m.	200- 8000 r.p.m.	200-8000 r.p.m.
	Back Spindle Hole Dia.	-	Ø33 mm	-
Back Spindle	Back Spindle Speed	-	6000 r.p.m.	-
	Max. Length for Front Ejection	-	80 mm	-
	Rapid Speed	18 M	18 M	18 M
Motors	Spindle Motor	5.5 kw	5.5 kw	5.5 kw
	Back Spindle Motor	-	1.5 kw	-
	X1, Y1, Z1 Axis Motor	0.5 kw	0.5 kw	0.5 kw
	Z2 Axis Motor	-	0.5 kw	-
	Coolant Pump	0.55 kw	0.55 kw	0.55 kw
	Lubrication	4 w	4 w	4 w
	Cross Spindle	-	-	0.75 kw
Machine Dimensions	Center Height	960 mm	960 mm	960 mm
	Weight	2270 kg	2770 kg	2288 kg
	Machine Dimension	2200 × 1140 × 1568 mm	2550 × 1140 × 1568 mm	2200 × 1140 × 1568 mm
Air Pressure	Air Pressure	5 kg/cm	5 kg/cm	5 kg/cm
	Air Supply	10 L/min	10 L/min	10 L/min

* We reserve the rights to change the design without any prior notification.

MACHINE SPECIFICATIONS

Items	DIAMOND 12B III	DIAMOND 12CSB III	DIAMOND 16B III	DIAMOND 16CSB III	DIAMOND 20B III	DIAMOND 20CSB III	DIAMOND 25B III	DIAMOND 25CSB III	
Working Range	Max. Machining Dia.	Ø12.7 mm	Ø12.7 mm	Ø16.5 mm	Ø16.5 mm	Ø20 mm	Ø26 mm	Ø26 mm	
	Max. Machining Length Per Chucking	200 mm	200 mm	200 mm	200 mm	200 mm	200 mm	200 mm	
	Max. Drilling Dia.(Main Spindle)	Ø7 mm	Ø7mm	Ø10 mm	Ø10 mm	Ø10 mm	Ø10 mm	Ø10 mm	
	Max. Drilling Dia.(Sub Spindle)	Ø7mm	Ø7 mm	Ø7 mm	Ø7 mm	Ø7 mm	Ø7 mm	Ø7 mm	
	Max. Tapping Dia.(Main Spindle)	M6	M6	M8	M8	M8	M8	M8	
O.D.Tooling	Number of Tools	6	6	6	6	6	6	6	
	Dimension	□12×12 ×120	□12×12×120	□12×12×120	□12×12×120	□12×12×120	□12×12×120	□12×12×120	
I.D. Tooling	Number of Tools	4	4	4	4	4	4	4	
	Dimension	10 mm (ER16)	10 mm (ER16)	10 mm (ER16)	10 mm (ER16)	10 mm (ER16)	10 mm (ER16)	10 mm (ER16)	
Cross Working Driven Tooling	Number of Tools	-	6	-	6	-	6	-	
	Dimension	-	10 mm (ER16)	-	10 mm (ER16)	-	10 mm (ER16)	-	
	Speed	-	200-6000 r.p.m.	-	200-6000 r.p.m.	-	200-6000 r.p.m.	-	
Front Working Driven Tooling	Number of Tools	-	3	-	3	-	3	-	
	Dimension	-	10 mm (ER16)	-	10 mm (ER16)	-	10 mm (ER16)	-	
	Speed	-	200-6000 r.p.m.	-	200-6000 r.p.m.	-	200-6000 r.p.m.	-	
Back I.D. Tooling	Number of Tools	4x4	4x4	4x4	4x4	4x4	4x4	4x4	
	Dimension	10 mm (ER16)	10 mm (ER16)	10 mm (ER16)	10 mm (ER16)	10 mm (ER16)	10 mm (ER16)	10 mm (ER16)	
Back Working Driven Tooling	Number of Tools	-	3	-	3	-	3	-	
	Dimension	-	7 mm (ER11)	-	7 mm (ER11)	-	7 mm (ER11)	-	
	Number of Tools	-	4	-	4	-	4	-	
Spindle	Dimension	-	10 mm (ER16)	-	10 mm (ER16)	-	10 mm (ER16)	-	
	Speed	-	200-6000 r.p.m.	-	200-6000 r.p.m.	-	200-6000 r.p.m.	-	
	Spindle Hole Dia.	Ø13 mm	Ø13 mm	Ø17 mm	Ø17 mm	Ø22 mm	Ø22 mm	Ø30 mm	
Back Spindle	Spindle Speed	200- 8000 r.p.m.	200- 8000 r.p.m.	200- 8000 r.p.m.	200- 8000 r.p.m.	200- 8000 r.p.m.	200- 8000 r.p.m.	200- 8000 r.p.m.	
	Main Spindle Indexing Angle	C axis	(Optional CS axis 0.001° indexing)	C axis	(Optional CS axis 0.001° indexing)	C axis	(Optional CS axis 0.001° indexing)	(Optional CS axis 0.001° indexing)	
Rapid Traverse	Spindle Hole Dia.	Ø13 mm	Ø13 mm	Ø17 mm	Ø17 mm	Ø22 mm	Ø22 mm	Ø30 mm	
	Spindle Speed	200-5000 r.p.m (200-8000 r.p.m Option built-in motor)							
	Max. Length for Front Ejection	50 mm	50 mm	50 mm	50 mm	50 mm	50 mm	50 mm	
Motors	Sub Spindle Indexing Angle	C axis	(Optional CS axis 0.001° indexing)	C axis	(Optional CS axis 0.001° indexing)	C axis	(Optional CS axis 0.001° indexing)	(Optional CS axis 0.001° indexing)	
	X1, Y1, Z1, X2, Z2	30 m/min							
	Spindle Motor	2.2 kw	2.2 kw	2.2 kw	2.2 kw	3.7 kw	3.7 kw	3.7 kw	
	Back Spindle Motor	2.2 kw (2.2 kw Option built-in motor)				2.2 kw (3.7 kw Option built-in motor)			
	X1, Y1, Z1, X2, Z2 Axis Motor	1 kw	1 kw	1 kw	1 kw	1 kw	1 kw	1 kw	
	Y2 Axis Motor	1 kw	1 kw	1 kw	1 kw	1 kw	1 kw	1 kw	
	Coolant Pump Motor	1 HP	1 HP	1 HP	1 HP	1 HP	1 HP	1 HP	
Lubrication Motor	4 w	4 w	4 w	4 w	4 w	4 w	4 w		
Machine Dimensions	Driven Tools Motor-fixed Arm	-	1.5 kw	-	1.5 kw	-	1.5 kw	-	
	Driven Tools Motor-back Replaced	-	0.4 kw	-	0.4 kw	-	0.4 kw	-	
	Toolholder Set (Option Y2 Axis)	-	1 kw	-	1 kw	-	1 kw	-	
Center Height	890 mm	890 mm	890 mm	890 mm	890 mm	890 mm	890 mm		

Swiss Type CNC Auto Lathe SIMPLICITY-Precision-Speed DURABILITY-Stability



**DIAMOND
CSL 25/32/42**



Cross spindle and bevel drill/mill tool holes will help you to do drilling, milling and tapping on cross slide and bevel.



Main spindle and back spindle can work simultaneously or separately.



The attachable CF spindle will be helpful to do special work.



**DIAMOND 12B III / 12CSB III
16B III / 16CSB III / 20B III / 20CSB III**



WATCH VDO



Po Ly Gim introduces the smallest swiss type CNC lathe : the diamond CSL 12-2Y. with a 12mm bar capacity and up to 10 working axes, the compact Diamond CSL 12-2Y doesn't compromise capability for size.

Among its unique features are two Y-axes and six fully programmable (360 degree) tools that work on both the main and sub-spindle. the diamond CSL 12-2Y is suitable for producing small electronics parts and is mill turn capable.

MACHINE SPECIFICATIONS

Items	DIAMOND 12 CSB III-S	DIAMOND 16 CSB III-S	DIAMOND 20 CSB III-S	DIAMOND 25 CSB III-S
Working Range	Max. machining Dia.	Ø12.7 mm	Ø16.5 mm	Ø20 mm
	Max. machining length per chucking	200 mm	200 mm	200 mm
	Max. drilling dia. (main spindle)	Ø7 mm	Ø10 mm	Ø10 mm
	Max. drilling dia. (sub spindle)	Ø7 mm	Ø7 mm	Ø7 mm
	Max. tapping dia. (main spindle)	M6	M8	M8
	Max. tapping dia. (sub spindle)	M6	M6	M6
	Number of tools	6	6	6
O.D. Tooling	Dimension	□ 12 x 12 x 120	□ 12 x 12 x 120	□ 12 x 12 x 120
	Number of tools	4	4	4
I.D. Tooling	Dimension	10 mm (ER16)	10 mm (ER16)	10 mm (ER16)
	Number of tools	6	6	6
Cross Working Driven Tooling	Dimension	10 mm (ER16)	10 mm (ER16)	10 mm (ER16)
	Speed	200 - 6000 r.p.m.	200 - 6000 r.p.m.	200 - 6000 r.p.m.
	Number of tools	3	3	3
Front Working Driven Tooling	Dimension	10 mm (ER16)	10 mm (ER16)	10 mm (ER16)
	Speed	200-6,000 rpm	200-6,000 rpm	200-6,000 rpm
	Number of tools	4 + 4	4 + 4	4 + 4
Back I.D. Tooling	Dimension	10 mm (ER16)	10 mm (ER16)	10 mm (ER16)
	Number of tools	3	3	3
	Dimension	7 mm (ER11)	7 mm (ER11)	7 mm (ER11)
Back Working Driven Tooling	Number of tools	4	4	4
	Dimension	10 mm (ER16)	10 mm (ER16)	10 mm (ER16)
	Speed	200-6,000 rpm	200-6,000 rpm	200-6,000 rpm
Spindle	Spindle hole dia.	Ø13 mm	Ø17 mm	Ø22 mm
	Spindle speed	200-8,000 rpm	200-8,000 rpm	200-8,000 rpm
	Main spindle indexing angle	C axis (Optional CS axis 0.001° indexing)	C axis (Optional CS axis 0.001° indexing)	C axis (Optional CS axis 0.001° indexing)
	Spindle hole dia.	Ø13 mm	Ø17 mm	Ø22 mm
	Spindle speed	200-5,000 rpm (200-8,000 rpm Option built-in motor)	200-5,000 rpm (200-8,000 rpm Option built-in motor)	200-5,000 rpm (200-8,000 rpm Option built-in motor)
Back Spindle	Max. length for front ejection	50 mm	50 mm	50 mm
	Sub spindle indexing angle	C axis (Optional CS axis 0.001° indexing)	C axis (Optional CS axis 0.001° indexing)	C axis (Optional CS axis 0.001° indexing)
	Spindle motor	2.2 kW (2.2 kW Option built-in motor)	2.2 kW (2.2 kW Option built-in motor)	2.2 kW (3.7 kW Option built-in motor)
Motors	X1, Y1, Z1, X2, Z2 axes motor	1 kW	1 kW	1 kW
	Y2 axis motor (option)	1 kW	1 kW	1 kW
	Coolant pump motor	1 HP	1 HP	1 HP
	Lubrication motor	4 W	4 W	4 W
	Driven tools motor	1.5kW(M70)/ 2.2kW(M80)	1.5kW(M70)/ 2.2kW(M80)	1.5kW(M70)/ 2.2kW(M80)
	Driven tools motorback replaced toolholder set (option Y2 axis)	1.5kW(M70)/ 2.2kW(M80)	1.5kW(M70)/ 2.2kW(M80)	1.5kW(M70)/ 2.2kW(M80)
Machine Dimensions	Center height	890 mm	890 mm	890 mm
	Weight (option Y2 axis)	1,920 kg	2,070 kg	2,170 kg
	Machine dimension	2440 x 1430 x 1650 (2690 x 1495 x 1890 option Y2 axis)	2440 x 1430 x 1650 (2690 x 1495 x 1890 option Y2 axis)	2440 x 1430 x 1650 (2690 x 1495 x 1890 option Y2 axis)
Air Pressure	Air pressure	5 kg / cm	5 kg / cm	5 kg / cm
	Air supply	10 L / min	10 L / min	10 L / min

MACHINE SPECIFICATIONS

Items	DIAMOND 25 CSL	DIAMOND 32 CSL	DIAMOND 42 CSL	
Working Range	Max. Turning Dia.	Ø26mm	Ø32mm	
	Max. machining length per chucking	250mm	250mm	
	Max. Drilling Dia.	Ø26mm	Ø26mm	
	Max. Tapping Dia.	M16	M16	
	O.D. Tooling (B axis with 3 pcs)	6	6	
	O.D. Tooling (B axis with 8 pcs)	7	7	
	O.D. Tool Dimension	□ 16x16x120	□ 16x16x120	
	(Front) I.D. Tooling (B axis with 3 pcs)	2	2	
	(Front) I.D. Toolin (B axis with 8 pcs)	3	3	
	Tooling System	Tool Dimension	13 mm (ER20)	13 mm (ER20)
(Back) I.D. Tooling		4	4	
Tool Dimension		13 mm (ER20)	13 mm (ER20)	
Cross Tooling		6	6	
Tool Dimension		13 mm (ER20)	13 mm (ER20)	
Speed		200-6000 r.p.m.	200-6000 r.p.m.	
(Opt.) Bevel Drill/Mill Tooling(B axis with 3 pcs)		3	3	
(Opt.) Bevel Drill/Mill Tooling(B axis with 8 pcs)		8	8	
Tool Dimension		13mm (ER20)	13mm (ER20)	
Speed		100-6000rpm	100-6000rpm	
Spindle	(Opt.) Front Drilling Tooling	2	2	
	Tool Dimension	13mm (ER20)	13mm (ER20)	
	Speed	200-6000rpm	200-6000rpm	
	(Opt.) Back Drilling Tooling	3	3	
	Tool Dimension	13mm (ER20)	13mm (ER20)	
	Speed	100-4000rpm	100-4000rpm	
	Spindle Hole Dia.	Ø26mm	Ø33mm	
	Spindle Speed	200-7000rpm	200-7000rpm	
	Indexing	C axis	C axis	
	(Opt.) CS Axis indexing	0.001°	0.001°	
Back Spindle	Back Spindle Hole Dia.	Ø25mm	Ø33mm	
	Back Spindle Speed	200-6000rpm	200-6000rpm	
	Indexing	5°	5°	
	(Opt.) C Axis indexing	C axis	C axis	
	Max. length for front ejection	70mm	70mm	
	Max. workpiece projection length from the back spindle	120mm	120mm	
	Max. Back Drilling Dia.	Ø16mm	Ø16mm	
	Max. Back Tapping Dia.	M12	M12	
	Rapid Traverse	X1, Z1, Y1, X2, Z2 Axes	18 or 30 m/min	18 or 30 m/min
	(Opt.) Y2 Axis	18 or 30 m/min	18 or 30 m/min	
Motors	Main Spindle Motor	3.7/5.5kW	3.7/5.5kW	
	Back Spindle Motor	2.2kW	2.2kW	
	X1, Z1, Y1, X2, Z2 Axes Motor	1.2kW	1.2kW	
	(Opt.) Y2, B Axes Motor	0.75kW	0.75kW	
	Cross driven spindle Motor	2.2kW	2.2kW	
	(Opt.) Bevel driven spindle Motor(B axis with 3 pcs)	1kW	1kW	
	(Opt.) Bevel driven spindle Motor(B axis with 8 pcs)	2.2kW	2.2kW	
	(Opt.) Back driven spindle Motor	0.75kW	0.75kW	
	(Opt. Y2 Axis) Back driven spindle Motor	1kW	1kW	
	Coolant Pump	0.75kw x 2	0.75kw x 2	
Machine Dimensions	Lubrication	4w x 2	4w x 2	
	Center Height	960mm	960mm	
	Weight	4550kg	4550kg	
Air	Machine Size	3030x1810x 1980 mm	3030x1810x 1980 mm	
	Air Pressure	5kg/cm	5kg/cm	
Air Supply	10L/min	10L/min		

MACHINE SPECIFICATIONS

Items	DIAMOND CSL 12-2 Y		DIAMOND CSL 16-2 Y		
	Y1	Y2	Y1	Y2	
Working Range	Max. Machining Dia.	Ø12.7 mm	Ø16.5 mm		
	Max. Machining Length Per Chucking	143 mm	143 mm		
	Max. Drilling Capacity	Ø7 mm	Ø10 mm		
Tooling System	Max. Tapping Capacity	M6	M8		
	O.D. Turning Tooling	4	4	2	
	O.D. Turning Tool Dimension	□ 10x10x100	□ 10x10x100	□ 10x10x100	□ 10x10x100
	I.D. Tool	5	5	5	
	I.D. Tool Dimension	7 mm (ER11)	10 mm (ER16)	10 mm (ER16)	
	Cross Tool (Power - Driven Tool)	5	5		
	Cross Tool Dimension	7 mm (ER11)	10 mm (ER16)		
	Cross Tool Speed	200-6000 r.p.m.	200-6000 r.p.m.		
	360° Automatic Rotary Driven Tool		6	6	
	360° Automatic Rotary Driven Tool Dimension		10 mm (ER16) x3	10 mm (ER16) x3	
360° Automatic Rotary Driven Tool Speed		7 mm (ER11) x3	7 mm (ER11) x3		
200-6000 r.p.m.		200-6000 r.p.m.			
Spindle	Spindle Hole Dia.	Ø13 mm	Ø17 mm		
	Spindle Speed	200-10,000 r.p.m.	200-10,000 r.p.m.		
Sub-Spindle	Sub-Spindle Hole Dia.		Ø13 mm	Ø17 mm	
	Sub-Spindle Speed		200-10,000 r.p.m.	200-10,000 r.p.m.	
	Sub-Spindle Max. Drilling Capacity.		Ø7 mm	Ø10 mm	
	Sub-Spindle Max. Tapping Capacity.		M6	M8	
Rapid Speed	A Axis		30 m/min	30 m/min	
	X1, Z1 Axis	30 m/min		30 m/min	
	Y1 Axis	30 m/min		30 m/min	
	X2, Y2, Z2 Axis		30 m/min	30 m/min	
Motor	Main Spindle (M65/700)	1.5 kw / 2.2 kw		1.5 kw / 2.2 kw	
	Sub-Spindle (M65/700)		1.5 kw / 2.2 kw	1.5 kw / 2.2 kw	
	Y1, Y2 Axis	1.0 kw	1.0 kw	1.0 kw	1.0 kw
	A, X1, X2, Z1, Z2 Axis	0.75 kw	0.75 kw	0.75 kw	0.75 kw
	B Axis		0.4 kw	0.4 kw	
	Rotary Tools / B Axis Rotary Tools	0.4 kw	0.4 kw	0.4 kw	0.4 kw
	Coolant Pump	1 H.P.		1 H.P.	
	Lubrication	25 W		25 W	
	Center Height	1050 mm		1050 mm	
	Weight	2580 kg		2680 kg	
Machine Dimensions	Dimension	2500x1200x1800 mm		2500x1200x1800 mm	
	Air Pressure	5 kg/cm		5 kg/cm	
Air Pressure	Air Supply	10 L/min		10 L/min	

Items	DIAMOND CSL426-2 Y		
	Y1 (System 1)	Y2 (System 2)	
Working Range	Max. Machining Dia.	Ø42 mm	Ø42 mm
	Max. Machining Length	280 mm	
	Max. Drilling Capacity	Ø30 mm	Ø30 mm
Tooling System	Max. Tapping Capacity	M16	M16
	O.D. Turning Tool	5	
	O.D. Turning Tool Dimension	□20x20x120	
	Cross Tool (power - driven tool)	4	
	Cross Tool Dimension	16 mm (ER25)	
Power Turret	Cross Tool Speed	200-6000 rpm	
	Power - driven Tool / Station		12
	O.D. Tool Dimension		□20 x 20
	I.D. Tool Dimension		Ø25 mm
	Max. O.D. Turning Tool / Station		6
	Max. I.D. bore Tool / Station		6
	Power - driven Tool Dimension		16 mm (ER25)
Spindle	Power - driven Tool Speed		200-4000 rpm
	Max. Radial Mill / Drill Tool / Station		12
	Max. Axial Mill / Drill Tool / Station		12
Sub-spindle	Spindle Hole Dia.	Ø42 mm	
	Spindle Speed	200-6000 rpm	
Rapid Speed	Sub-spindle Hole Dia.		Ø42 mm
	Sub-spindle Speed		200-6000 rpm
	Max. Length for Front Ejection		120 mm
	Sub-spindle Max. Drilling Dia.		Ø30 mm
Travel	Sub-spindle Max. Tapping Dia.		M16
	A axis	30m/min	30m/min
	X1, Z1, Y1 axes	30m/min	30m/min
Motors	X2, Z2, Y2 axes		30m/min
	A axis		460 mm
	X1 axis	45 mm	
	Z1 axis	300 mm	
	Y1 axis	360 mm	
Machine	X2 axis		130 mm
	Z2 axis		480 mm
	Y2 axis		185 mm
	Main Spindle	7.5 kW	
	Sub-spindle		7.5 kW
	Y1, Y2 axes	1.5 kW	2.2 kW
	A, X1, Z1, X2, Z2 axes	1.0 kW	1.0 kW
Rotary Tools	2.2 kW	2.2 kW	
Dimensions	Coolant Pump	1 HP	1 HP
	Lubrication	25 w	25 w
Air	Center Height		960 mm
	Weight		6380 kgs
Air Pressure	Dimension		3000x1800x1980 mm
	Air Pressure		5 kg/cm
Air Supply	Air Supply		10 L/min

CNC Lathe Multi-Spindle CNC Lathe



MULTI-25 / 25S

MACHINE SPECIFICATIONS

Items	MULTI 25	MULTI 25-S
Max. Machining Dia.	Ø26 mm	Ø26 mm
Max. Machining Length	Bar diameter x 3	Bar diameter x 3
Max. Cross Travel (X Axis)	170 mm	170 mm
Max. Longitudinal Travel (Z Axis)	150 mm	150 mm
Bore of Spindle	34 mm	34 mm
Max. Bar Feeding Dia.	26 mm	26 mm
Type of Collet	161 E	161 E
Spindle Motor	2.2 kw	2.2 kw
Spindle Speed Range	100-5000 r.p.m.	100-5,000 r.p.m.
Sub-Spindle Motor (Option)	1.1 kw	1.1 kw
Sub-Spindle Speed Range (Option)	100-5,000 r.p.m.	100-5,000 r.p.m.
Rapid Traverse Speed (X & Z Axis)	15 m/min	15 m/min
Min. Input Unit	0.001 mm	0.001 mm
Cutting Tool Size	□16 mm	□16 mm
Max. Bore Size of Tool	Ø20 mm	Ø20 mm
X1/Z1/Z2/A2/Z3 Axes Motor	0.75 kw	0.75 kw
A3 Axes Motor (Option Sub-Spindle)	0.75 kw	0.75kw
X2/Y2/X3 Axes Motor	0.5 kw	0.5kw
Number of Multi-Spindle Tools	3 pc	6 pc
Coolant Pump Motor	1/2 H.P.	1/2 H.P.
Hydraulic Pump Motor	1 H.P.	1 H.P.
Machine Size (L x W x H)	1658x1362x1530mm	1658x1362x1530mm
Machine Size-Option Sub-Spindle (L x W x H)	2000x1359x1657mm	2000x1359x1657mm
Machine Net Weight (Without Chip Conveyor)	1220 kgs	1320 kgs
Machine Net Weight (Option Sub-Spindle, Without Chip Conveyor)	1880 kgs	1980 kgs

CNC Lathe T-plus Series

T-plus 42/52/60



Gang type tool disc
configure 4 pcs
boring toolholder.
If also can option
8-position servo turret.

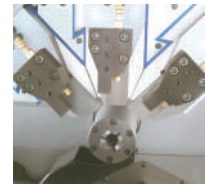

3 channel synchronous
tool holder can
setting 3 pcs tools.



3 channel synchronous
tool holder can setting
6 pcs tools.



Spindle mounting
collet chuck.

MACHINE SPECIFICATIONS

Items	Single Spindle			Double Spindle with power Turret			Double Spindle with Servo Turret		
	T-PLUS 42	T-PLUS 52	T-PLUS 60	T-PLUS 42	T-PLUS 52	T-PLUS 60	T-PLUS 42	T-PLUS 52	T-PLUS 60
Max. machining dia. (with 3 jaws chuck)	Ø130 mm	Ø300 mm	Ø350 mm	Ø130 mm	Ø300 mm	Ø350 mm	Ø130 mm	Ø300 mm	Ø350 mm
Max. machining length (with tall-stock)	400 mm	400 mm	400 mm	200 mm	200 mm	200 mm	200 mm	200 mm	200 mm
Swing over cross slide	350 mm	350 mm	350 mm	350 mm	350 mm	350 mm	350 mm	350 mm	350 mm
X axis travel	200 mm	200 mm	200 mm	220 mm	220 mm	220 mm	200 mm	200 mm	200 mm
Z axis travel	480 mm	480 mm	480 mm	360 mm	360 mm	360 mm	360 mm	360 mm	360 mm
A axis travel				450 mm	420 mm	420 mm	450 mm	420 mm	420 mm
Y axis travel	70 mm	70 mm	70 mm	70 mm	70 mm	70 mm			
Bore of spindle	55 mm	60 mm	88 mm	55 mm	60 mm	88 mm	55 mm	60 mm	88 mm
Max. bar feeding dia.	42 mm	52 mm	60/80(opt.) mm	42 mm	52 mm	60/80 (opt.) mm	42 mm	52 mm	60/80 (opt.) mm
Spindle nose	A2-5 mm	A2-6 mm	A2-6/A2-8(opt.) mm	A2-5 mm	A2-6 mm	A2-6/A2-8 (opt.) mm	A2-5 mm	A2-6 mm	A2-6/A2-8 (opt.) mm
Sub-Spindle nose				A2-5 mm	A2-5 mm	A2-5 mm	A2-5 mm	A2-5 mm	A2-5 mm
Spindle chuck	6" inch	8" inch	10"/12"(opt.) inch	6" inch	8" inch	10"/12" (opt.) inch	6" inch	8" inch	10"/12" (opt.) inch
Sub-Spindle chuck				6" inch	6" inch	6" inch	11kW/15HP	11kW/15HP	15kW/20HP
Spindle motor	11kW/15HP	11kW/15HP	15kW/20HP	7.5/11 kW	7.5/11 kW	7.5/11, 11/15 (opt.) kW	6" inch	6" inch	6" inch
Sub-Spindle motor				2.2/3.7 kW	2.2/3.7 kW	2.2/3.7 kW	3.7kW/5HP	3.7kW/5HP	3.7kW/5HP
Z axis motor	1 kW	1 kW	1 kW				1 kW	1 kW	1 kW
X axis / Opt. Y axis motor	1.5 kW	1.5 kW	1.5 kW						
Z,X,A axes motor				1.6 kW	1.6 kW	1.6 kW	1.5 kW	1.5 kW	1.5 kW
Driven tools motor for power turret	3.7kW/5HP	3.7kW/5HP	3.7kW/5HP				3.7kW/5HP	3.7kW/5HP	3.7kW/5HP
Spindle speed	100-6000 rpm	100-4000 rpm	100-3500, 100-3000 (opt.) rpm	100-6000 rpm	100-4000 rpm	100-3500, 100-3000 (opt.) rpm	100-6000 rpm	100-4000 rpm	100-3500, 100-3000 (opt.) rpm
Sub-Spindle speed				100-6000 rpm	100-6000 rpm	100-6000 rpm	100-6000 rpm	100-6000 rpm	100-6000 rpm
Rapid traverse (X, Z A axes)	12 m/min	12 m/min	12 m/min	12 m/min	12 m/min	12 m/min	12 m/min	12 m/min	12 m/min
Min. input unit	0.001 mm	0.001 mm	0.001 mm	0.001 mm	0.001 mm	0.001 mm	0.001 mm	0.001 mm	0.001 mm
Cutting tool size(opt. power turret)	Ø25(Ø20)	Ø25(Ø20)	Ø25(Ø20)	Ø25 mm	Ø20 mm	Ø20 mm	Ø25(Ø20) mm	Ø25(Ø20) mm	Ø25(Ø20) mm
Max. bore size of tool	Ø32 mm	Ø32 mm	Ø32 mm	Ø25 mm	Ø25 mm	Ø25 mm	Ø32 mm/Ø25 mm	Ø32 mm/Ø25 mm	Ø32 mm/Ø25 mm
Coolant pump motor	1HP mm	1HP mm	1HP mm	1HP	1HP	1HP	1HP	1HP	1HP
Dimension(Attached Chip conveyor)	340x189x184 cm	340x189x184 cm	340x189x184 cm				340x189x184 cm	340x189x184 cm	340x189x184 cm
Dimension(Without Chip conveyor)	257x189x184 / 300x215x200 (opt. Y axis) cm	257x189x184 / 300x215x200 (opt. Y axis) cm	257x189x184 / 300x215x200 (opt. Y axis) cm	300x215x 200 cm	300x215x 200 cm	300x215x200 cm	257x189x184 cm	257x189 x184 cm	257x189x184 cm
Weight	3588/3788 (opt. Y axis) kg	3628/3828 (opt. Y axis) kg	3789/3989 (opt. Y axis) kg	4500 kg	4600 kg	4700 kg	4300 kg	4400 kg	4500 kg

CNC Lathe With Y Axis

PLG Series

A CNC Lathe Without Power Turret
But Function Supper Then Power Turret



PLG-42Y

MACHINE SPECIFICATIONS

Items	PLG-42Y	PLG-52Y	PLG-60Y
Max. Machining Dia.	42 mm	52 mm	60 mm
Max. Machining Length	Bar diameter x 3	Bar diameter x 3	Bar diameter x 3
Swing Over Cross Slide	200 mm	200 mm	200 mm
X Axis	190 mm	190 mm	190 mm
Z Axis	300 mm	300 mm	300 mm
Y Axis	300 mm	300 mm	300 mm
Bore of Spindle	55 mm	60 mm	85 mm
Bar Capacity	42 mm	52 mm	60 mm
Spindle Nose	A2-5	A2-6	A2-6
Collet Type	173E/ 42mm	177 Eor 185E / 52mm	185E / 60mm
Spindle Motor	11 kw / 15 H.P.	11 kw / 15 H.P.	15 kw / 20 H.P.
Z, Y Axis Motor	1 kw	1 kw	1 kw
X Axis Motor	1.5 kw	1.5 kw	1.5 kw
Cross Spindle Driven Tools Motor	2.2 kw	2.2 kw	2.2 kw
Front off-Center Driven Tools Motor	2.2 kw	2.2 kw	2.2 kw
Spindle Speed	100-5000 r.p.m.	100-4000 r.p.m.	100-3500 r.p.m.
Cross Spindle Speed	200-5000 r.p.m.	200-5000 r.p.m.	200-5000 r.p.m.
Front off-Center Driven Tool Speed	200-5000 r.p.m.	200-5000 r.p.m.	200-5000 r.p.m.
Rapid traverse speed(X, Z, Y Axis)	12 m/min	12 m/min	12 m/min
Min. Input Unit	0.001 mm	0.001 mm	0.001 mm
O.D. Tooling	6	5	5
O.D. Tool Dimension	Ø20 x 20 x 110	Ø20 x 20 x 110	Ø20 x 20 x 110
I.D. Tooling	6	6	6
I.D. Tool Dimension	Ø25 mm	Ø25 mm	Ø25mm
I.D. Tool Max. Drilling Dia.	Ø25 mm	Ø25 mm	Ø25 mm
I.D. Tool Max. Tapping Dia.	M16	M16	M16
Cross Driven Tooling	4	4	4
Cross Driven Tooling Dimension	16 mm (ER25)	16 mm (ER25)	16 mm (ER25)
Cross Driven Tool Max. Drilling Dia.	Ø16 mm	Ø16 mm	Ø16 mm
Cross Driven Tool Max. Tapping Dia.	M10	M10	M10
Front off-Center Driven Tooling	4	4	4
Front off-Center Driven Tool Dimension	16 mm (ER25)	16 mm (ER25)	16 mm (ER25)
Front off-Center Driven Tool Max. Drilling Dia.	Ø16 mm	Ø16 mm	Ø16 mm
Front off-Center Driven Tool Max. Tapping Dia.	M10	M10	M10
High Pressure Coolant Pump	1 H.P.	1 H.P.	1 H.P.
Hydraulic Pump	1 H.P.	1 H.P.	1 H.P.
Dimension	2490x1690x1955mm	2490x1690x1955mm	2490x1690x1955mm
Weight	3000 kgs	3000 kgs	3000 kgs

Super Compact CNC With Y Axis



MINI-88

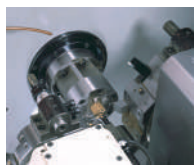

Double turret : main turret for O.D. turning, sub turret for I.D. turning; two turrets work simultaneously.

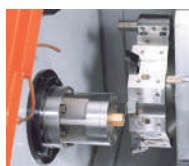

Servo turret as standard accessory to increase turning efficiency.



**MINI-88Y
(With Y Axis)**



Y axis design to mount tool holder instead of power turret.



Part catcher.



spindle mounting collet chuck.

MACHINE SPECIFICATIONS

Items	MINI-88	MINI-88-20
Max. Machining Dia.	60 mm (with chuck) 26 mm (with collet chuck)	21 mm
Max. Machining Length	120 mm	100 mm
Swing Over Cross Slide	120 mm	120 mm
Max. Cross Trave (X Axis)	170 mm	170 mm
Max. Longitudinal Travel (Z Axis)	170 mm	170 mm
Bore of Spindle	34 mm	23 mm
Max. Bar Feeding Dia.	26 mm	21 mm
Spindle Nose	Ø85 mm	-
Hydraulic Chuck	4"	-
Spindle Motor	2.2 kw / 3 H.P.	2.2 kw / 3 H.P.
Spindle Speed Range	100-5000 r.p.m.	100-8000 r.p.m.
Rapid Traverse Speed (X & Z Axis)	15 m/min	15 m/min
Min. Input Unit	0.001 mm	0.001 mm
Cutting Tool Size	16 mm	16 mm
Max. Bore Size of Tool	Ø20 mm	Ø16 mm
Coolant Pump Motor	1/4 H.P.	1/4 H.P.
Machine Dimension (L x W x H)	1200 x 1000 x 1500 mm	1100 x 1000 x 1500 mm
Machine Net Weight	1058 kgs	1008 kgs

MACHINE SPECIFICATIONS

Items	MINI-88Y
Max. Machining Dia.	25 mm
Max. Machining Length	Bar diameter x 3
X Axis	165 mm
Z Axis	150 mm
Y Axis	148 mm
Bore of Spindle	34 mm
Bar Capacity	26 mm
Spindle Nose	Ø85 mm
Collet Type	161 E / 25 mm
Spindle Motor	2.2 kw / 3 H.P.
X, Z, Y Axis Motor	0.75 kw
Cross and Front off-Center Driven Tools Motor	0.75 kw
Spindle Speed	100-6000 r.p.m.
Cross Spindle Speed	200-6000 r.p.m.
Front off-Center Driven Tool Speed	200-6000 r.p.m.
Spindle Indexing	5°
Rapid Traverse Speed (X, Z, Y Axis)	12 m/min
Min. Input Unit	0.001 mm
O.D. Tooling	6
O.D. Tool Dimension	□ 12 X 12 X 100
I.D. Tooling	4
I.D. Tool Dimension	Ø20 mm
I.D. Tool Max. Drilling Dia.	Ø20 mm
I.D. Tool Max. Tapping Dia.	M8
Cross Driven Tooling	4
Cross Driven Tooling Dimension	10 mm (ER16)
Cross Driven Tool Max. Drilling Dia.	Ø10 mm
Cross Driven Tool Max. Tapping Dia.	M8
Front off-Center Driven Tooling	4
Front off-Center Driven Tool Dimension	10 mm (ER16)
Front off-Center Driven Tool Max. Drilling Dia.	Ø10 mm
Front off-Center Driven Tool Max. Tapping Dia.	M8
Coolant Pump	1/2 H.P.
Hydraulic Pump	1/2 H.P.
Dimension	1420 x 1210 x 1710 mm
Weight	1158 kgs



CNC Lathe Machine

YLM-6 / 8A Series



YLM-6



YLM-8A

- Spindle speed : 6000/4500 rpm
- Spindle speed (full power output) : 750/563 rpm
- Swing over bed : 460 mm
- Max turning length : 412/400 mm

YLM-8B / 10A Series



YLM-8B



YLM-10A

- Spindle speed : 4500/3500 rpm
- Spindle speed (full power output) : 375/233 rpm
- Swing over bed : 700 mm
- Max turning length : 600/586 mm

WATCH VDO



FEATURE

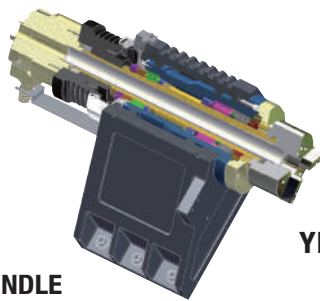

YLM-8A

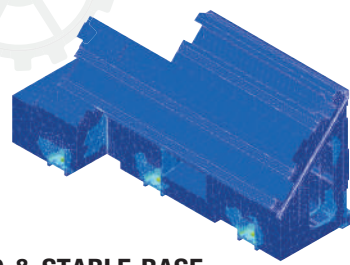

YLM-10A

RIGID & PRECISE SPINDLE

- The maximum spindle speed is up to 6000 rpm.
- Spindle front slide is specially adopted large diameter roller bearings and angular contact ball bearing to achieve the best cutting capacity. There's optimal span and balancing support between the front and rear roller bearings. This design resists the radial load and provides excellent cutting condition in high and low speed.
- Strong headstock utilizes heat symmetrical and dissipation slot design to reduce thermal deformation value and raise stable cutting accuracy.

RUGGED & STABLE BASE

- The powerful one-unity-shaped base structure is professionally developed by 3D-CAD and FEM analysis to let the inner walls be perfectly strengthened with rigid ribs. It increases whole machine's rigidity and stability, keeps long term of reliable cutting accuracy and extends tooling life.
- Low gravity center of 45° slant bed design makes chips remove easily, load and unload conveniently. It also boosts machining capacity and decreases deformation.



HIGH SPEED SERVO TURRET

- The turret rotation and indexing is driven by a powerful servo motor which provides accurate positioning, fast and stable tool change.
- Servo turret deploys three curvic couplings clutch and hydraulic clamping system to gain high torque output and low noise.

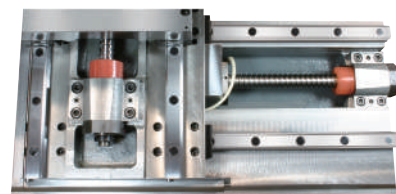

YLM-8A

HIGH PRECISION BALL SCREW & LINEAR GUIDE

- Heat treatment and precision ground ball screw assures excellent and longer sustained accuracy. Each axis has pre-extension design which offers greater machining rigidity and reliability.
- Latest and durable linear guide provides smooth and fast movement.
- 30 m/min.(1181ipm) rapid traverse reduces non-cutting time and increases productivity.

MACHINE SPECIFICATIONS

ITEMS	SPECIFICATION	YLM-6	YLM-8A	YLM-8B	YLM-10A
Capacity	Swing over bed	Ø460 mm (Ø18.1")		Ø700 mm (Ø27.6")	
	Swing over cross slide	Ø208 mm (Ø8.2")		Ø495 mm (Ø19.5")	
	Std. turning dia.	Ø200 mm (Ø7.9")		Ø495 mm (Ø19.5")	
	Max turning dia.	Ø400 mm (Ø15")		Ø490 mm (Ø20.7")	
	Max turning length	412 mm (Ø16.2")	400 mm (Ø15.7")	600 mm (23.6")	586 mm (23")
Travel	Distance between center	490 mm (Ø19.3")		710 mm (28")	
	X axis	210 (200+10) mm / 8.3"(7.9"+0.4")		260 (235+25) mm/10.2"(9.3"+0.9")	
	Z axis	412 mm (Ø16.2")	400 mm (Ø15.7")	600 mm (23.6")	586 mm (23")
Spindle	Guide way	Linear guides		Linear guides	
	Spindle nose	A2-5	A2-6	A2-6	A2-8
	Spindle bearing dia.	Ø90 mm (Ø3.5")	Ø100 mm (Ø3.9")	Ø100 mm (Ø3.9")	Ø130 mm (Ø5.1")
	Max Spindle speed	6000 rpm	4500 rpm	4500 rpm	3500 rpm
	Spindle bore	56 mm (2.2")	62 mm (2.4")	62 mm (2.4")	90 mm (3.5")
Turret	Draw tube bore	45 mm (1.77")	52 mm (2")	52 mm (2")	75 mm (3")
	Chuck size	6 inch / 3-Jaw	8 inch / 3-Jaw	8 inch / 3-Jaw	10 inch / 3-Jaw
	Turret type	mm/inch		mm/inch	
	Driven way	servo motor		servo motor	
	No. of tool	12 / 10 (opt.)		12	
Tailstock	Tool shank size	□ 20 mm (□ 0.79") / □ 25 mm (□ 0.98") (opt.)		□ 25 mm (□ 0.98")	
	Max. boring bar dia.	Ø25 mm / Ø40 mm (opt.)	Ø32 mm / Ø40 mm (opt.)	Ø40 mm (Ø1.57")	
	Driven way	Programmable hydraulic		Programmable hydraulic	
Feedrate	Guide way	Linear guides		Linear guides / Square way (opt.)	
	Center MT#	MT#4		MT#4	MT#5
	Travel	405 mm (15.9")		680 mm (26.7")	
Servo Motor	X/Z axis rapid feedrate	30 m/min. (1181 ipm)		30 m/min. (1181 ipm)	
	Cutting feedrate	1260 mm/min.(49.6 ipm)		1260 mm/min.(49.6 ipm)	
	Spindle motor (P-type)	9/11 kW		11/15 kW	15/18.5 kW
CNC Controller	Spindle speed (full power output)	750 rpm	563 rpm	375 rpm	233 rpm
	Axis motor	X:1.2 kW, Z:1.8 kW		X:3.0 kW, Z:3.0 kW	
	Servo motor	500 W (0.67hp)		850 W (1.1hp)	
Motor	FANUC 0iT		FANUC 0iT		
	Chip conveyor motor	188 W(0.25hp)		188 W(0.25hp)	
	Coolant pump motor	700 W(0.93hp)		700 W(0.93hp)	
Dimension	Hydraulic pump motor	1510 W(2hp)		1510 W(2hp)	
	Floor space (L x W x H)	2400x1610x1850mm (119.3" x 63.4"x88.2")		2950x1890x1990mm (116.1" x 74.4" x 78.3")	
	Net weight	3000kgs (6600 lbs)		4650kgs (10230 lbs)	

To keep improvement new design, the specifications will change without prior notice.

CNC Drilling & Tapping Center

- Spindle speed 60 ~ 10,000 rpm (Standard)
- Spindle speed
 - OP : 12,000 / 15,000 / 20,000 rpm
 - OP : 24,000 rpm (Mitsubishi)
 - OP : 30,000 rpm
- Rigid tapping : 4,000 rpm
- Spindle nose taper BT30 (STD) / BBT30 (OP)
- 3 axes rapid traverse X, Y : 48 m/min, Z: 60 m/min
- Fully enclosed (Heat insulated) electric cabinet.
- High speed mechanical ATC system T-T : 1.6 sec
- Directly coupled spindle drive system

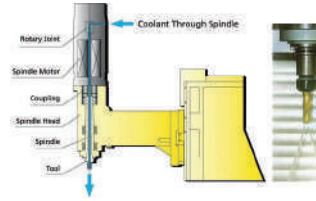

COOLANT THROUGH SPINDLE



R4530 / R5630



R5030



R5140



HIGH RIGIDITY

Machine Structure : Being manufactured from high rigidity cast iron, the machine structure is computer analyzed for maximum rigidity user, fast travel and heavy duty machining conditions.

MACHINE SPECIFICATIONS

MACHINE SPECIFICATION	UNIT	R4530	R5030	R5140	R5630
Table size	mm	500 x 320	550 x 320	600 x 410	650 x 410
Max. Table load	kg	200	200	250	200
X, Y, Z, axis travel	mm	450x300x300	500x300x300	510x400x460	560x400x300
Table to spindle nose	mm	170~470	170~470	140 ~ 600	180 ~ 480
Spindle taper		BT30	BT30	BT40	BT30
Pull stud		MAS403 P30T-1(45°)			
Spindle motor	Mitsubishi	kw 5.5 / 3.7	5.5 / 3.7	7.5 / 5.5	5.5 / 3.7
	Fanuc	kw 3.7 / 2.2	3.7 / 2.2	7.5 / 5.5	3.7 / 2.2
	Siemens	kw 5.6 / 3.7	5.5 / 3.7		5.5 / 3.7
X drive motor	Mitsubishi	kw 1.0	1.0	1.5	1.5
	Fanuc	kw 1.6	1.6	1.6	1.6
	Siemens	kw 2.3	2.3		2.3
Y drive motor	Mitsubishi	kw 1.0	1.0	1.5	1.5
	Fanuc	kw 1.6	1.6	1.6	1.6
	Siemens	kw 2.3	2.3		2.3
Z drive motor	Mitsubishi	kw 2.0	2.0	3.0	3.0
	Fanuc	kw 3.0	3.0	3.0	3.0
	Siemens	kw 3.3	3.3		3.3
Spindle speeds	rpm	10000	10000	8000	10000
X, Y, Z, axis rapid traverse	m/min	48 / 48 / 60	48 / 48 / 60	36 / 36 / 36	48 / 48 / 60
Tool capacity	no.	12	14 / 20 (OP)	12	14 / 20 (OP)
Max. tool weight	kg	3	3	3	3
Max. tool length	mm	200	200	250	200
ATC time (T-T)	sec	M1.6 / F2.5	M1.6 / F2.5	M2.2 / F3.2	M1.7 / F2.6
Net weight	kg	2100	2200	3500	2600
Floor space	mm	1200x2230x2480	1500x2230x2480	1560x2670x2825	1590x2640x2500

CONTROLLER SPECIFICATIONS	Mitsubishi	FANUC
Max. controlled axis	5	4
Max. simultaneous axis	4	4
Standard controlled axis	3	3
Program storage length	512kb	512kb
Work piece coordinates	54	54
Max. variable number	700	600
Tool offset pairs	400	400
Conversations programming	NAVI	Manual guide Oi
Monitor	8.4" TFT LCD	
Multi-language display	O	O
ABS servo motor	O	O
Tool length compensation	O	O
Tool path compensation	O	O
On-screen drafting	O	O
High speed data serve & Ethernet	O	OP
High speed & high accuracy machining control mode	G05.1 Q1	
Interface	RS232/ RJ45	
Memory card input / output	O	O

O : Standard X : None OP : Option



R6030 / R6040



R12030 / R12040

HIGH SPEED HIGH EFFICIENCY MACHINERY

- HIGH SPEED SPINDLE
- HIGH RESPONSE SERVO SYSTEM
- HIGH SPEED 3 AXES RAPID TRAVERSE
- Spindle speed 60-8,000 rpm (STD)
- Spindle speed 60-12,000 rpm (OPT)
- Rigid tapping 3,000 rpm
- Spindle nose taper BT 40
- 3 axes rapid traverse X, Y, Z : 36, 36, 36 m/min
- Dual electric cases (Heat insulated)
- High speed mechanical ATC system T-T : 2.2 sec (R600) / 2.2 sec (R5140)

MACHINE SPECIFICATIONS

MACHINE SPECIFICATION		UNIT	R6030	R600	R6040	R12030	R12040
Table size		mm	700 x 410	700 x 410	700 x 410	1300 x 530	1300 x 530
Max. Table load		kg	200	250	250	400	400
X, Y, Z, axis travel		mm	600x400x300	600x400x400	600x400x400	1200x500x300	1200x500x400
Table to spindle nose		mm	155 ~ 455	120 ~ 520	140 ~ 540	170 ~ 470	140 ~ 540
Spindle taper			BT30	BT40	BT40	BT30	BT40
Pull stud			MAS403 P30T-1(45°)	MAS403 P40T-1(45°)	MAS403 P40T-1(45°)	MAS403 P30T-1(45°)	MAS403 P40T-1(45°)
Spindle motor	Mitsubishi	kw	5.5 / 3.7	7.5 / 5.5	7.5 / 5.5	5.5 / 3.7	7.5 / 5.5
	Fanuc	kw	3.7 / 2.2	7.5 / 5.5	7.5 / 5.5	3.7 / 2.2	7.5 / 5.5
	Siemens	kw	5.5 / 3.7		10.5 / 7.0		
X drive motor	Mitsubishi	kw	1.5	1.5	1.5	3.5	3.5
	Fanuc	kw	1.6	1.6	1.6	3.0	3.0
	Siemens	kw	2.3		2.3		
Y drive motor	Mitsubishi	kw	1.5	1.5	1.5	3.5	3.5
	Fanuc	kw	1.6	1.6	1.6	3.0	3.0
	Siemens	kw	2.3		2.3		
Z drive motor	Mitsubishi	kw	3.0	3.0	3.0	3.5	3.5
	Fanuc	kw	3.0	3.0	3.0	4.0	4.0
	Siemens	kw	3.3		3.3		
Spindle speeds		rpm	10000	8000	8000	10000	8000
X, Y, Z, axis rapid traverse		m/min	48 / 48 / 60	36 / 36 / 36	48 / 48 / 48	48 / 48 / 48	48 / 48 / 48
Tool capacity		no.	14 / 20 (OP)	12	14	14	14
Max. tool weight		kg	3	3	3	3	3
Max. tool length		mm	200	250	250	200	250
ATC time (T-T)		sec	M1.7 / F 2.6 (T-T)	M2.2 / F 3.2 (T-T)	M2.2 / F 3.2 (T-T)	M2.0 / F3.0 (T-T)	M2.5 / F3.5 (T-T)
Net weight		kg	3100	3550	3550	4500	4620
Floor space		mm	1700x2750x2500	1700x2750x2750	1700x2750x2940	2900x3270x2940	2900x3270x3000

CONTROLLER SPECIFICATIONS	Mitsubishi	FANUC
Max. controlled axis	5	4
Max. simultaneous axis	4	4
Standard controlled axis	3	3
Program storage length	512kb	512kb
Work piece coordinates	54	54
Max. variable number	700	600
Tool offset pairs	400	400
Conversations programming	NAVI	Manual guide Oi
Monitor	8.4" TFT LCD	
Multi-language display	O	O
ABS servo motor	O	O
Tool length compensation	O	O
Tool path compensation	O	O
On-screen drafting	O	O
High speed data serve & Ethernet	O	OP
High speed & high accuracy machining control mode	G05.1 Q1	
Interface	RS232/ RJ45	
Memory card input / output	O	O

O : Standard X : None OP : Option

CNC Production Center

A new generation of drilling & Tapping Center

SPINDLE SPEED

- BT30 : 10,000 rpm / 15,000 rpm (OP/ Mitsubishi) / 12,000 rpm (OP/ FANUC)
- BT40 : 8,000 rpm / 12,000 rpm (OP)

NUMBER OF TOOLS

- BT30 : 20
- BT40 : 24

RAPID TRAVERSE

- BT30 : 48 / 48 / 60 m/min
- BT40 : 48 / 48 / 48 m/min

RIGID TAPPING

- BT30 : 4000 rpm
- BT40 : 3000 rpm

POSITIONING ACCURACY

- JIS B6338 : 0.005 / 300 mm
- VDI 3441 P : 0.012 mm

REPEATABILITY ACCURACY

- JIS B6338: ± 0.003 mm
- VDI 3441 P : 0.010 mm



A6030 / A6040



A7040

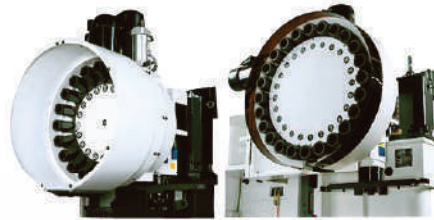

THE FASTEST SPINDLE ACCELERATION

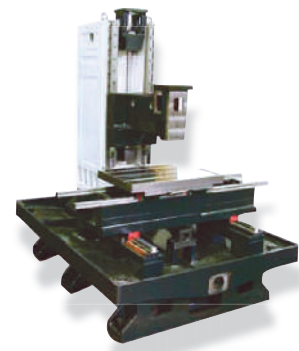

TRANSMISSION SYSTEM

A new generation of drilling & Tapping Center



R12030 / R12040

SPINDLE SPEED (STD)

- BT30 : 10,000 rpm
- BT40 : 8,000 rpm

SPINDLE SPEED (OP)

- BT30 : 12,000/15,000/20,000 rpm
24,000 rpm (Mitsubishi)
- BT40 : 12,000 rpm

NUMBER OF TOOLS

- BT30 : A6030 : 20T
- BT40 : A6040 : 24T

RAPID TRAVERSE

- BT30 : 48 / 48 / 60 m/min
- BT40 : 48 / 48 / 48 m/min

RIGID TAPPING

- BT30 : 4000 rpm
- BT40 : 3000 rpm

POSITIONING ACCURACY

- JIS B6338 : 0.005/ 300 mm
- VDI 3441 P : 0.012 mm

REPEATABILITY ACCURACY

- JIS B6338 : ± 0.003 mm
- VDI 3441 P : 0.010 mm

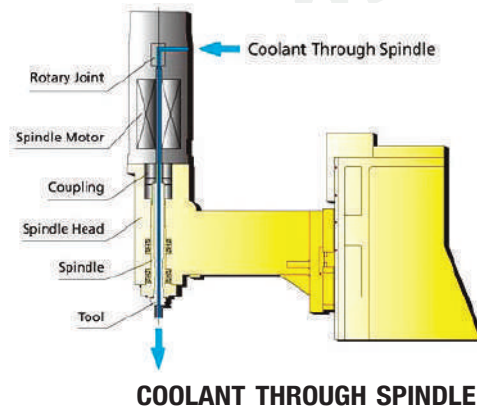

WATCH VDO



MACHINE SPECIFICATIONS

MACHINE SPECIFICATION		UNIT	A6030	A6040	A7030	A7040
Table size		mm	700 x 410	700 x 410	800 x 430	800 x 430
Max. Table load		kg	200	250	250	250
X, Y, Z, axis travel		mm	600x400x350	600x400x600	700x400x350	700x400x550
Table to spindle nose		mm	155~505	150~750	180~530	120~670
Spindle taper			BT30	BT40	BT30	BT40
Pull stud			MAS403 P30T-1(45°)	MAS403 P40T-1(45°)	MAS403 P30T-1(45°)	MAS403 P40T-1(45°)
Spindle motor	Mitsubishi	kw	5.5 / 3.7	7.5 / 5.5	5.5 / 3.7	7.5 / 5.5
	FANUC	kw	3.7 / 2.2	7.5 / 5.5	5.5 / 3.7	7.5 / 5.5
	Siemens	kw	5.5 / 3.7	10.5 / 7.0	5.5 / 3.7	10.5 / 7.0
X drive motor	Mitsubishi	kw	1.5	1.5	1.5	1.5
	FANUC	kw	1.6	1.6	1.6	1.6
	Siemens	kw	2.3	2.3	3.3	3.3
Y drive motor	Mitsubishi	kw	1.5	1.5	3.5	3.5
	FANUC	kw	1.6	1.6	3.0	3.0
	Siemens	kw	2.3	2.3	3.3	3.3
Z drive motor	Mitsubishi	kw	3.0	3.0	3.5	3.5
	FANUC	kw	3.0	3.0	4.0	4.0
	Siemens	kw	3.3	3.3	4.9	4.9
Spindle speeds		rpm	10000	8000	10000	8000
X, Y, Z, axis rapid traverse		m/min	48 / 48 / 60	48 / 48 / 48	48 / 48 / 60	48 / 48 / 48
Magazine capacity			20+1	24+1	20+1	24+1
Max. tool weight		kg	4	5	4	5
Max. tool length		mm	200	250	200	250
ATC time		sec	2.2 (T-T)	2.2 (T-T)	2.2 (T-T)	2.2 (T-T)
Net weight		kg	3200	3700	3810	3980
Floor space		mm	1700x2750x2360	1800x2750x2785	2910x1900x2465	2910x1900x2700

CONTROLLER SPECIFICATIONS

CONTROLLER SPECIFICATIONS	O : Standard	OP : Option
	MITSUBISHI	FANUC
Max. controlled axis	5	4
Max. simultaneous axis	4	4
Standard controlled axis	3	3
Program storage length	512kb	512kb
Work piece coordinates	54	54
Macro common variables	700	700
Tool offset pairs	200	400
Conversations programming	NAVI	Manual guide Oi
Monitor	8.4" TFT LCD	
Multi-language display	O	O
ABS servo motor	O	O
Tool length compensation	O	O
Tool path compensation	O	O
On-screen drafting	O	O
High speed data serve & Ethernet	OP (64SM)	OP
High speed high precision command	OP (64SM)	O
Interface	RS232	
Memory card input / output	OP (64SM)	O

O : Standard X : None OP : Option

MACHINE SPECIFICATIONS

MACHINE SPECIFICATION		UNIT	A12030	A12040
Table size		mm	1300 x 530	1300 x 530
Max. Table load		kg	400	400
X, Y, Z, axis travel		mm	1200x500x350	1200x500x550
Table to spindle nose		mm	170~520	140~690
Spindle taper			BT30	BT40
Pull stud			MAS403 P30T-1(45°)	MAS403 P40T-1(45°)
Spindle motor	Mitsubishi	kw	5.5 / 3.7	7.5 / 5.5
	Fanuc	kw	3.7 / 2.2	7.5 / 5.5
X drive motor	Mitsubishi	kw	3.5	3.5
	Fanuc	kw	3.0	3.0
Y drive motor	Mitsubishi	kw	3.5	3.5
	Fanuc	kw	3.0	3.0
Z drive motor	Mitsubishi	kw	3.5	3.5
	Fanuc	kw	4.0	4.0
Spindle speeds		rpm	10000	8000
X, Y, Z, axis rapid traverse		m/min	48/48/48	48/48/48
Magazine capacity			20+1	24+1
Max. tool weight		kg	4	5
Max. tool length		mm	200	250
ATC time		sec	2.2(T-T)	2.4(T-T)
Net weight		kg	4570	4700
Floor space		mm	2900x3270x2625	2900x3270x2885

CONTROLLER SPECIFICATIONS

CONTROLLER SPECIFICATIONS	O : Standard	OP : Option
	MITSUBISHI	FANUC
Max. controlled axis	5	4
Max. simultaneous axis	4	4
Standard controlled axis	3	3
Program storage length	1280m	1280m
Work piece coordinates	54	54
Macro common variables	700	600
Tool offset pairs	400	400
Conversations programming	NAVI	Manual guide Oi
Monitor	8.4" TFT LCD	
Multi-language display	O	O
ABS servo motor	O	O
Tool length compensation	O	O
Tool path compensation	O	O
On-screen drafting	O	O
High speed data serve & Ethernet	O	OP
High speed & high accuracy machining control mode	G05.1 Q1	
Interface	RS232/RJ45	
Memory card input / output	O	O

CNC Production Center (Double Work Stations)

A new generation of drilling & Tapping Center

RIGID TAPPING

- BT30 : 4,000 rpm
- BT40 : 3,000 rpm

POSITIONING ACCURACY

- JIS B6338 : ± 0.003 mm
- VDI 3441 P : 0.010 mm

REPEATABILITY ACCURACY

- JIS B6338 : ± 0.003 mm
- VDI3441 P: 0.010 mm

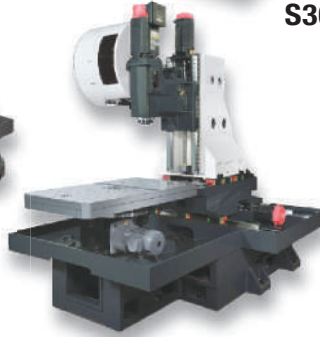

S3030

S6040

DIRECT DRIVE SPINDLE



BT30



BT40



S500

- Spindle speed 60~10,000 rpm (Standard)
- Spindle speed 60~15,000 rpm (Optional)
- Low inertia spindle and spindle motor
- Rigid tapping : 4,000 rpm
- Tool holder : BT30 (STD) / BBT (OPT)
- Rapid traverse X, Y : 36 m/min, Z : 30 m/min
- High speed arm type ACT time (T-T : 2.3 sec)
- Work table change time : 4.5 sec
- Direct drive spindle motor



FULL-TRAVEL COLUMN STRUCTURE AND UNIQUE ATC

MACHINE SPECIFICATIONS

MACHINE SPECIFICATION	UNIT	S3030	S500	S6040
Table size	mm	400 x 250 x 2pcs	600 x 400 x 2pcs	700 x 400 x 2pcs
Max. table load	kg	100	250	250
X, Y, Z, axis travel	mm	300 x 250 x 250	500 x 400 x 350	600 x 400 x 500
Table to spindle nose	mm	180~430	180 ~ 530	180~680
Spindle taper		BT30	BT30	BT40
Pull stud		MAS403 P30T-1(45°)	MAS403 P30T-1 (45°)	MAS403 P40T-1(45°)
Spindle motor	Mitsubishi	kw 5.5 / 3.7	5.5 / 3.7	7.5 / 5.5
	Fanuc	kw 3.7 / 2.2	3.7 / 2.2	7.5 / 5.5
	Siemens	kw 5.5 / 3.7	5.5 / 3.7	10.5 / 7.0
X drive motor	Mitsubishi	kw 1.5	1.5	3.5
	Fanuc	kw 1.6	1.6	3.0
	Siemens	kw 2.3	2.3	3.3
Y drive motor	Mitsubishi	kw 1.5	1.5	3.5
	Fanuc	kw 1.6	1.6	3.0
	Siemens	kw 2.3	2.3	3.3
Z drive motor	Mitsubishi	kw 1.5	1.5	3.5
	Fanuc	kw 1.6	1.6	4.0
	Siemens	kw 2.3	3.3	4.9
Spindle speeds	rpm	10000	10000	8000
X, Y, Z, axis rapid traverse	m/min	48 / 48 / 48	36 / 36 / 48	36 / 36 / 48
Magazine capacity		14 / 20 (OP)	20+1	24+1
Max. tool weight	kg	3	3	5
Max. tool length	mm	200	200	250
ATC time (T-T)	sec	1.9 / F2.6	2.2	3.1
APC time	sec	3	4.5	5
Net weight	kg	3350	5250	6600
Floor space	mm	2760x1730x2420	4130 x 2046 x 2370	3660 x 2582 x 2780

CONTROLLER SPECIFICATIONS

CONTROLLER SPECIFICATIONS	O : Standard OP : Option		
	mitsubishi	FANUC	SIEMENS
Max. controlled axis	5	4	4
Max. simultaneous axis	4	4	4
Standard controlled axis	3	3	3
Program storage length	512kb	512kb	3M
Work piece coordinates	54	54	100
Max. variables number	700	600	300
Tool offset pairs	400	400	128/256
Conversations programming	NAVI	Manual guide Oi	Program guide shopmill (OP)
Monitor	8.4" TFT LCD		10.4" LCD
Multi-language display	O	O	O
ABS servo motor	O	O	O
Tool length compensation	O	O	O
Tool path compensation	O	O	O
On-screen drafting	O	O	O
High speed data serve & ethernet	O	OP	O
High speed & high accuracy machining control mode	G05.1 Q1		Cycle 832
Interface	RS232/RJ45		RJ45
Memory card input / output	O	O	O

T-SLOT

	S3030	S500	S6040
T-SLOT	3 pcs	4 pcs	4 pcs
A	800	1100	1400
B	290	315	415
C	400	600	700
D	700	1000	1200
E	45	50	55
F	80	100	125
G		200	180
H		300	350
I		Ø50 ^{±0.03}	Ø50
J	300	500	600
K	250	400	400

CNC Tapping / Machining Center

- Table size 2100x430 mm
- Standard spindle speeds 10000 rpm
- Optional spindle speeds 12000/15000/20000/24000 rpm
- Spindle taper BT30
- Tools capacity 20 pcs
- X/Y/Z axis travel 2000/400/350 mm
- Directly coupled spindle drive system



E20030

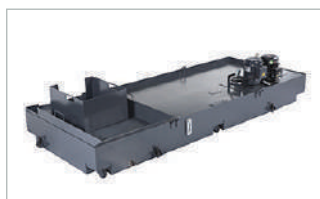

Water tank

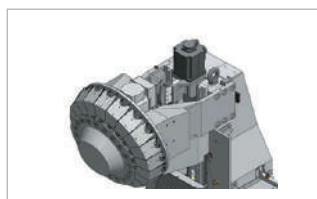

Servo ATC



Naked Machine

- Tool change time supplied with Mitsubishi controller and standard 60Hz power. For electrical requirements other than this standard, please contact one of our personnel.
- The company reserves the right to modify the specifications / design, subject to change without further notice.
- Actual specifications, based on order content.

MACHINE SPECIFICATIONS

MACHINE SPECIFICATIONS		UNIT	E20030
Table size		mm	2100 x 430
Max. Table load		kg	800
X, Y, Z axis travel		mm	2000 x 400 x 350
Spindle nose to table		mm	150~500
Spindle taper			BT30
Pull stud			MAS403 P30T-1(45°)
Spindle motor	Mitsubishi	kw	5.5
	Fanuc	kw	5.5
	Siemens	kw	5.6
X drive motor	Mitsubishi	kw	3.5
	Fanuc	kw	3.5
	Siemens	kw	2.3
Y drive motor	Mitsubishi	kw	1.5
	Fanuc	kw	1.6
	Siemens	kw	2.3
Z drive motor	Mitsubishi	kw	2
	Fanuc	kw	2
	Siemens	kw	3.3
Spindle speed		rpm	10000
X, Y, Z axis rapid traverse		m/min	36 / 48 / 60
Tools capacity		pcs	20
Max. tool weight		kg	3
Max. tool length		mm	200
ATC time (T-T)		sec.	2.2
Tank volume		L	292
Net weight		mm	7800
Floor space		mm	4420 x 2970 x 2775

Horizontal CNC Tapping Center

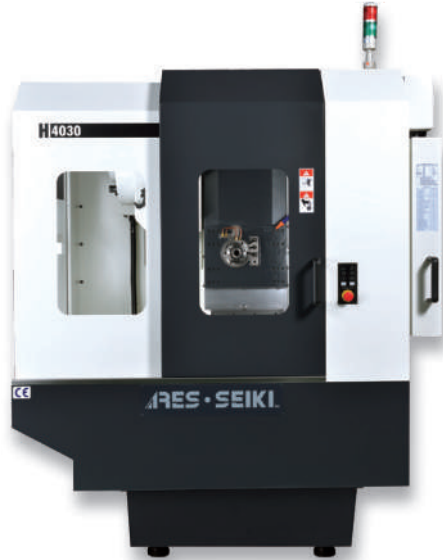

H4030

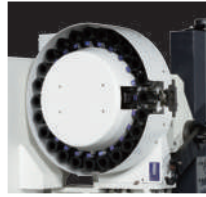

24 tool cam type ATC to provide stable tool change system

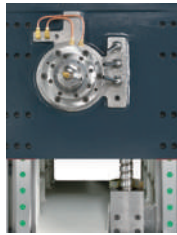

3 axes are equipped with roller guide ways and big spacing (span) to strengthen spindle machining performance



The rotary operation box is easy for operators operating



H4040P

CONTROLLER SPECIFICATION

CONTROLLER SPECIFICATION	O : Standard		OP : Option
	Mitsubishi	Fanuc	Siemens
Max. simultaneous axis	4	4	4
Standard controlled axis	4	4	4
Program storage length	512 kb	512 kb	5 M
Work piece coordinates	54	54	100
Max. variable number	700	600	300
Tool offset pairs	400	400	128 / 256
Conversational programming	NAVI	Manual guide Oi	Program guide shopmill (OP)
Monitor	8.4" TFT LCD / 10.4" TFT LCD (OP)		10.4" TFT LCD
Multi-language display	0	0	0
ABS servo motor	0	0	0
Tool length compensation	0	0	0
Tool radius compensation	0	0	0
On-screen drafting	0	0	0
High speed data server & ethernet	0	OP	0
High speed & high accuracy machining control mode	G05 P10000	G05.1 Q1	CYCLE832
Interface	RS232 / RJ45		RJ45
Memory card input / output	0	0	0
USB input / output	0	0	0

MACHINE SPECIFICATIONS

MACHINE SPECIFICATION	UNIT	HD403-5X	H4030	H4040	H4040P	HM4040	HM4040P
Table size	mm	Ø170	400 x 400	400 x 400	400 x 400 x 2 PCS	400 x 400	400 x 400 x 2 PCS
Max. table load	kg	30	200	200	300	400	400
Max. workpiece dimension (Øxheight)	mm	Ø220 x 300	Ø480 x 540	Ø480 x 540	Ø560 x 700	Ø560 x 700	Ø560 x 700
Min indexing precision of table	deg	0.001	0.001	0.001	0.001	0.001	0.001
Cumulative indexing precision of table	sec	20	20	20	20	10	10
C axis repeatability accuracy	sec	4					
Slope angle of A axis	deg	±100°					
Cumulative indexing precision of A axis	sec	30					
A axis repeatability accuracy	sec	8					
A / C axis Speed	rpm	150 / 200					
Table repeatability accuracy	sec		4	4	4	4	4
Drive system for table exchange					Cam type		Servo motor
Max. rotation diameter of table					1370		1370
Max. rotation diameter of APC							
X, Y, Z axis travel	mm	400 / 610 / 380	400 / 450 / 380	400 / 450 / 380	500 x 450 x 450	560 x 500 x 560	560 x 500 x 560
X, Y, Z axis rapid traverse	m/min	48 / 60 / 48	48 / 60 / 48	48 / 48 / 48	48 / 48 / 48	48 / 48 / 48	48 / 48 / 48
3 axes rapid travel	m/min	48 / 60 / 48					
3 axes bidirectional accuracy of positioning	mm	0.005 / 300			VDI 3441		
3 axes bidirectional repeatability of positioning	mm	±0.003			VDI 3441		
Spindle speeds	rpm	12000	10000	8000	8000	10000	10000
Spindle taper			BT30			BT40	
Pull stud			MAS403 P30T-1(45°)			MAS403 P40T-1(45°)	
Spindle driving					Direct		
Spindle center to surface of table	mm	190-570	90-540	110-560	100-550	105-605	105-605
Spindle nose to table center	mm	-135-475	190-570	110-490	160-610	100-660	100-660
Spindle motor	Mitsubishi	kw	5.5 / 3.7	5.5 / 3.7	7.5 / 5.5	15 / 11	15 / 11
	Fanuc	kw	5.5 / 3.7	5.5 / 3.7	7.5 / 5.5	15 / 11	15 / 11
	Siemens	kw	5.5 / 3.7	5.5 / 3.7	10.5 / 7.0	10.5 / 7.0	16.5 / 11
X Drive motor	Mitsubishi	kw	1.5	1.5	1.5	4.5	4.5
	Fanuc	kw	1.6	1.6	1.6	4.0	4.0
	Siemens	kw	2.3	2.3	2.3	4.9	4.9
Y Drive motor	Mitsubishi	kw	3.0	3.0	3.0	4.5	4.5
	Fanuc	kw	3.0	3.0	3.0	4.0	4.0
	Siemens	kw	3.3	3.3	4.8	4.9	4.9
Z Drive motor	Mitsubishi	kw	1.5	1.5	1.5	2.2	4.5
	Fanuc	kw	1.6	1.6	1.6	4.0	4.0
	Siemens	kw	2.3	2.3	2.3	4.9	4.9
B Drive motor	Mitsubishi	kw	1.5	1.5	1.5	2.2	2.2
	Fanuc	kw	1.6	1.6	1.6	3.0	3.0
	Siemens	kw	2.3	2.3	2.3	2.3	2.3
A axis cutting torque	Nm	48					
B axis speed	rpm		16.6	16.6	27.7	33.3	33.3
C axis cutting torque	Nm	29					
Tools capacity	tools	24+1	24+1	30+1	30+1	40+1	60+1
Magazine capacity							
Max. tool weight	kg	4	4	5	5	7	7
Max. tool length	mm	200	200	250	250	300	300
Max. tool diameter (alternate pocket empty)	mm	65 (80)	65 (80)	78 (120)	78 (120)	75 (150)	75 (150)
ATC time (T-T)	sec	2.5	2.5	3.0	2.7	4.0	4.0
Tool change type					Arm type		
Tank volume	L	200	200	200	200	380	380
Coolant pump rate	W	600 x 2pcs	600	600	600	600	600
Coolant pump flow rate	l/min	136	136	136	136	136	136
Chip flush pump rate	W		600	600	600	930	1320
Chip flush pump flow rate	l/min		136	136	250	250	250
Chip flush type			Flushing type				
Auto. Chip conveyor			OP				
Net weight	kg	3700	3700	3850	5700	8150	10300
Floor space	mm	1835 x 2593 x 2471	1835 x 2593 x 2407	2000 x 2670 x 2475	2030 x 4200 x 2450	2550 x 4050 x 2730	2575 x 4680 x 2730



A5X403



- Rotary table diameter Ø255 mm
- A, C axis are driven by servo motor
- Hydraulic brake system



A5MT170



CAPTO C6

5-AXIS CNC TAPPING CENTER

Compact mechanical construction & 3 axes are equipped with roller guide ways suitable for medical equipment, aerospace equipment, 3C, automobile, motorcycle...etc.



Rotary table



Naked Machine

MACHINE SPECIFICATIONS

Machine Specification	Unit	A5X403	A5X404	A5MT170
Table size	mm	Ø255	Ø320	Ø170
Max. Table load	kg	50	75	70 (0°~45°) 40 (45°~90°)
Max. Workpiece dimension (Øx height)	mm	Ø360 x 250	Ø448 x 250	Ø400 x 200
Min Indexing precision of c axis rotary	degree	0.001	0.001	0.001
Cumulative indexing precision of C axis	sec	15	15	20
C axis repeatability accuracy	sec	4	6	8 / 6
Slope angle of A axis	degree	±110	+120 / - 40	30 -120
Cumulative indexing precision of A axis	sec	60	45	
A axis repeatability accuracy	sec	8	8	
Max. Speeds for A, C axis	rpm	33.3	13.3 / 22.2	13.3 / 2000
X, Y, Z axis travel	mm	400 x 500 x 400	400 x 500 x 450	400 x 500 x 400
3 axes rapid traverse	m/min	48 / 48 / 48	48 / 48 / 48	48 / 48 / 48
3 axes bidirectional accuracy of positioning	mm	VDI 3441	VDI 3441	VDI 3441
3 axes bidirectional repeatability of positioning	mm	VDI 3441	VDI 3441	VDI 3441
Spindle speeds	rpm	10000	8000	12000
Spindle taper		BT30	BT40	CAPTO C6
Pull stud		MAS 403 P30T-1(45°)		
Spindle Driven		Direct-drive		
Spindle nose to table	mm	30~430	40 ~ 490	20~420
Spindle center to Z path	mm	570	570	564
Spindle motor	Mitsubishi	kw	5.5 / 3.7	7.5 / 5.5
	Fanuc	kw	5.5 / 3.7	7.5 / 5.5
X Drive motor	Mitsubishi	kw	1.5	1.5
	Fanuc	kw	1.6	1.6
Y Drive motor	Mitsubishi	kw	1.5	2.2
	Fanuc	kw	1.6	2.7
Z Drive motor	Mitsubishi	kw	3.0	3.0
	Fanuc	kw	3.0	3.0
A Drive motor	Mitsubishi	kw	1.5	3.5
	Fanuc	kw	1.6	4.0
C Drive motor	Mitsubishi	kw	1.0	1.5
	Fanuc	kw	1.0	1.6
Magazine capacity	no.	20+1	24+1	24+1
Max. tool weight	kg	4	5	8
Max. tool length	mm	200	250	250
Max. tool diameter	mm	60 (80)	80 (120)	90 (150)
ATC time (T~T)	sec	2.2	2.4	4.4
Tool change Type		Arm type	Arm type	Arm type
Tank volume	ℓ	260	260	260
Coolant pump rate	w	600 x 2pcs	600 x 2pcs	600 x 2pcs
Flow rate	ℓ/min	136	136	136
Chip flush type		Flushing type	Flushing type	Flushing type
Auto. chip conveyor		OP	OP	OP
Net weight	kg	3900	4300	4300
Floor space	mm	1970 x 3032 x 2700	2170 x 3032 x 2657	2180x2500x3290

CONTROLLER SPECIFICATION

Controller Specifications	O : Standard	OP : Option
	Mitsubishi	Fanuc
Max. Controlled axis	5	5
Max. simultaneous axis	4	4
Standard controlled axis	5	5
Program storage length	512kb	512kb
Work piece coordinates	54	54
Max. Variable number	700	600
Tool offset pairs	400	400
Conversational programming	NAVI	Manual guide Oi
Monitor	8.4" TFT LCD / 10.4" TFT LCD (OP)	
Multi-language display	0	0
ABS servo motor	0	0
Tool length compensation	0	0
Tool path compensation	0	0
On-screen drafting	0	0
High speed data server & ethernet	0	OP
High speed & high accuracy machining control mode	G05.1 Q1	
Interface	RS232/RJ45	
Memory card input / output	0	0

CNC Profile Machining Center

PIC SERIES



Pratic-machine-bed



Pratic Operate system



Pratic-tool-magazine

WATCH VDO



MACHINE SPECIFICATIONS

MODEL	PIC SERIES		
TRAVELS	X-Axis	2500 / 4500 / 6500 mm	
	Y-Axis	450 mm	
	Z-Axis	400 mm	
SPINDLE	Maximum speed	12000 rpm	
	Taper	BT30 / SK30 / CAT30 Ø100mm (Outer diameter)	
TOOL MAGAZINE	Type	Arm type	
	Capacity	16 Pcs	
	Automatic tool change time	6 sec	
AXIS FEED RATES	Rapid on X	60 m/min	
	Rapid on Y	28 m/min	
	Rapid on Z	28 m/min	
	X/Y/Z cutting feed rate	15000 mm/min	
OPERATING SYSTEM		FANUC	SIEMENS
MOTOR POWER	Rated Power	5.5 kw	8 kw
	X axis Deiven Motor	3.0 kw	2.7 kw
	Y axis Deiven Motor	1.8 kw	2.7 kw
	Z axis Deiven Motor	1.8 kw	3.1 kw
LUBRICATION AND COOLING SYSTEM	Lubrication system	Automatic lubrication system	
	Coolant System	Water cooling	
ACCURACY	X-Axis positioning accuracy	0.05 mm	
	Y-Axis positioning accuracy	0.02 mm	
	Z-Axis positioning accuracy	0.02 mm	
	X-Axis repeat positioning accuracy	0.01 mm	
	Y/Z-Axis repeat positioning accuracy	0.01 mm	
MECHANICAL SPECIFICATION	Required pneumatic pressure	6 kg /cm ²	
	Machine height	3300 mm	
	Machine covered area	4800-9200 x 2900 mm	
	Machine weight	6000-9500 kg	

PIC SERIES

3 Axis CNC profile machining center
With high speed and high precision design, suitable for various lengths of aluminum, copper and non-metal frame.

1. The machine bed is fabricated from heavy gauge steel and the moving column is manufactured from high quality cast iron, allowing for solid support for the column and workpieces.
2. Moving column design features increased machining efficiency and accuracy.
3. 3 axes adopt high precision guideways.
4. Y/Z axis ball screws are direct coupled with drive motors, featuring no backlash, high transmission efficiency and high accuracy.
5. Automatic lubricator delivers lubrication oil to all linear guideways and ballscrews.

Product Description

The PIC model CNC machining center has capability function of milling, drilling, tapping,

PRATIC uses International CNC controller system for this model.

Machining for various lengths of aluminum frame, copper frame and etc. Adopted a high speed and high-precision design mode.

Equipped with a chip conveyor,

This PIC model is widely used in electronic appliance, customized furniture and other aluminum frame processing.

PYE-CNC2500

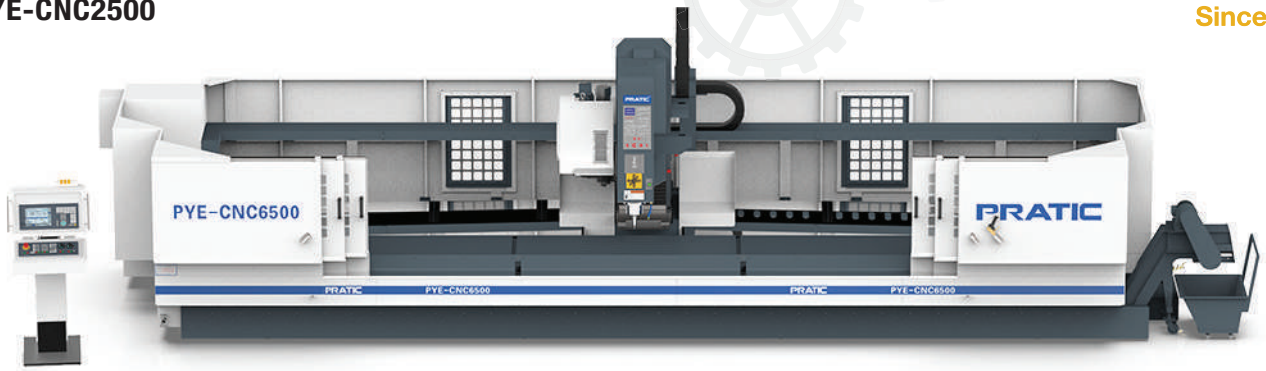

Disc type tool magazine



Chain chip conveyor



Lubrication system



High-performance and robust spindle system meets the most challenging modern processing needs of a wide range of metal materials

The spindle unit is particularly efficient, highly flexible and robust, perfect for universal use. BT/SK/CAT 40 standard taper gives the tool greater stability and balance at high speeds, higher level of static stiffness, ensures the machining precision.



Casting iron bed with strong shock absorption capacity and high physical stability

The casting iron machine bed undergoes a perfect heat treatment process to eliminate residual stress, with sufficient reinforcement plates and three rows of supporting feet ensures the rigidity.



Top-class numerical control system with high processing stability

- The Siemens and Fanuc CNC system is adopted
- With powerful functions and full-level data transmission
- Adopts a modular and open architecture design with high scalability
- Increase the flexibility and productivity of the machine tool



Intensified moving column structure brings higher rigidity and higher precision

The intensified moving column structure, together with the increased contact surface of the rail and slide block, reduces the deformation of the X-axis, and ensures the high rigidity and precision machining of the machine tool.

MACHINE SPECIFICATIONS

BT50/SK50/CAT50 Spindle					
	Items	Unit	PYE-CNC2500B	PYE-CNC4500B	PYE-CNC6500B
Travel	X-axis	mm	2500	4500	6500
	Y-axis	mm		650	
	Z-axis	mm		700	
	Distance from spindle nose to table surface	mm		130-830	
Worktable	Size (Length*Width)	mm	2500x650	4510x650	6520x650
	Max. load	kg/m ²	1200	1400	1600
	T-slot (Number/Width/Center distance)	mm		6/18/100	
Spindle	Type	/		Mechanical	
	Rated power	kW		15/17	
	Max. speed	rpm		8000	
	Taper	/		BT/SK/CAT50	
Feedrates	Rapid on X/Y/Z	m/min		60/28/28	
	X/Y/Z Cutting Feed Rate	m/min		15	
	Type	/		Disc type	
Tool Magazine	Capacity	pcs.		16	
	Tool-to-tool time	sec		2	
	Machine Height	mm		3100	
Dimension	Covering Area	mm	6900*3100	8700*3200	10900*3200
	Machine Weight	kg	12000	16500	17000

BT40/SK40/CAT40 Spindle					
	Items	Unit	PYE-CNC2500	PYE-CNC4500	PYE-CNC6500
Travel	X-axis	mm	2500	4500	6500
	Y-axis	mm		650	
	Z-axis	mm		700	
	Distance from spindle nose to table surface	mm		130-830	
Worktable	Size (Length*Width)	mm	2500x650	4510x650	6520x650
	Max. load	kg/m ²	1200	1400	1600
	T-slot (Number/Width/Center distance)	mm		6/18/100	
Spindle	Type	/		Mechanical	
	Rated power	kW		11/13	
	Max. speed	rpm		10000	
	Taper	/		BT/SK/CAT40	
Feedrates	Rapid on X/Y/Z	m/min		60/28/28	
	X/Y/Z Cutting Feed Rate	m/min		15	
	Type	/		Disc type	
Tool Magazine	Capacity	pcs.		24	
	Tool-to-tool time	sec		2	
	Machine Height	mm		3100	
Dimension	Covering Area	mm	6900*3100	8700*3200	10900*3200
	Machine Weight	kg	12000	16500	17000

CNC Profile Machining Center

Machine Parameter

The parameter are for reference only, subject to Technical Agreement



PDE4D SERIES:

1. The machine structure is manufactured from high quality cast iron, allowing for solid support for the column and workpieces.
2. Moving column design features increased machining efficiency and accuracy.
3. B-axis rotation within ± 90 degree achieves multi-angle machining with high accuracy.
4. 3 axes adopt high precision guide ways.
5. Y/Z axis ball screws are direct coupled with drive motors, featuring no backlash, high transmission efficiency and high accuracy.
6. Automatic lubricator delivers lubrication oil to all linear ways and ball screws.

PDE4D-CNC2500

MACHINE SPECIFICATIONS

MODEL SERIES			PDE4D SERIES					
MODEL NAME			PDE4D-CNC2500		PDE4D-CNC4500		PDE4D-CNC6500	
	Unit		FANUC	SIEMENS	FANUC	SIEMENS	FANUC	SIEMENS
Basic parameter	Number of Axis	/	4 Axis		4 Axis		4 Axis	
	Size of Worktable	mm	2500*550		4500*550		6500*550	
	Maximum Loading	kg/m ²	1000		1000		1000	
	Working Area	mm	2500*550		4500*550		6500*550	
	Bed	/	Casting Iron Bed		Casting Iron Bed		Casting Iron Bed	
Travels	X-axis	mm	2500		4500		6500	
	Y-axis	mm	550		550		550	
	Z-axis	mm	700		700		700	
	B-Axis	/	$\pm 90^\circ$		$\pm 90^\circ$		$\pm 90^\circ$	
Spindle	Standard Type	/	Motorized		Motorized		Motorized	
	Rated Spindle Driven Motor Power(S1)	kW	16	20	16	20	16	20
	Max. Driven Motor Power(S6)	kW	18.5	24	18.5	24	18.5	24
	Rated torque(S1)	N.m	30	35	30	35	30	35
	Maximum torque(S6)	N.m	38	42	38	42	38	42
	Maximum Speed	rpm	18000		18000		18000	
	Taper	/	BBT40		BBT40		BBT40	
Tool Magazine	Type	/	Disc Type		Disc Type		Disc Type	
	Capacity	pcs	24		24		24	
	Tool-to-tool time	secs	2		2		2	
Axis Feed Rates	Rapid on X	m/min	60		60		60	
	Rapid on Y	m/min	28		28		28	
	Rapid on Z	m/min	28		28		28	
	X/Y/Z Cutting Feed Rate	m/min	15		15		15	
Motor Power	Spindle Driven Motor	kW	16	20	16	20	16	20
	X Driven Motor	kW	3	3.1	3	3.1	3	3.1
	Y Driven Motor	kW	1.8	3.1	1.8	3.1	1.8	3.1
	Z Driven Motor	kW	3	3.1	3	3.1	3	3.1
Lubrication and Cooling System	Lubrication System	/	Automatic		Automatic		Automatic	
	Coolant System	/	Water Cooling		Water Cooling		Water Cooling	
Accuracy	X-Axis Repositioning Accuracy	mm	0.01		0.01		0.01	
	Y/Z-Axis Repositioning Accuracy	mm	0.01		0.01		0.01	
Mechanical Specification	Required Pneumatic Pressure	kg/cm ²	6		6		6	
	Machine Height	mm	3200		3200		3200	
	Covering Area	mm	6700*2850		8710*2850		10700*2850	
	Machine Weight	kg	10500		12500		14700	

TRAVEL	
X-Axis	2500-6500 mm (*can be customized)
Y-Axis	550 mm
Z-Axis	700 mm
B-Axis	$\pm 90^\circ$
SPINDLE	
Rated Power	20/16 kW
Maximum Speed	18000 rpm
Taper	BBT40/SK40/CAT40
TOOL MAGAZINE	
Type	Disc type
Capacity	24 pcs
OPERATION SYSTEM	
Brand	SIEMENS/FANUC

SAMPLES

AEROSPACE



AUTOMOTIVE



EV BATTERY



MACHINERY MANUFACTURING

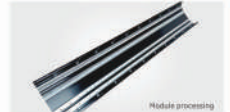

PDE4D-CNC6500

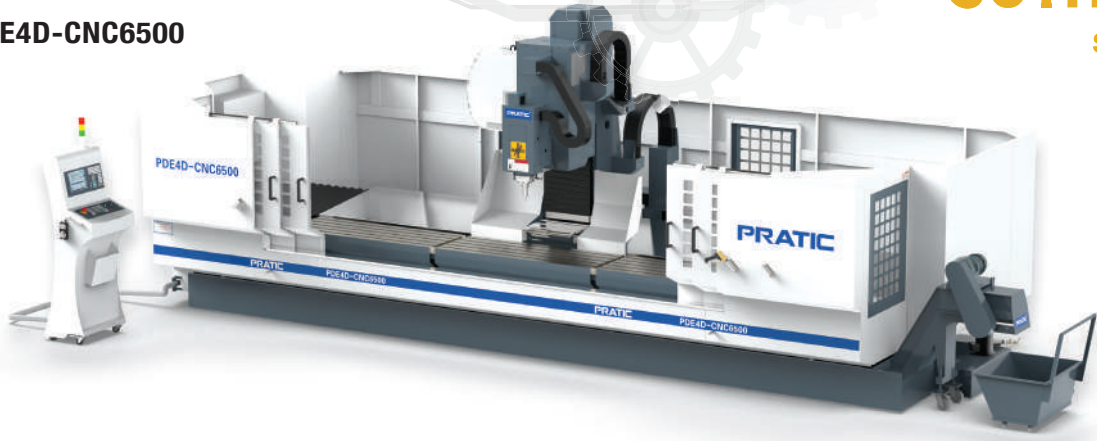

TECHNICAL FEATURES



Casting iron machine bed with strong shock absorption capacity and high physical stability

The machine bed is built with casting iron and undergoes a perfect heat treatment process to eliminate residual stress. Each casting has reasonable and sufficient reinforcement plates. Three rows of supporting feet are used to ensure the gravity rigidity of the center of the equipment.



Siemens & Fanuc numerical control system with high processing stability

The powerful internationally renowned numerical control system, ahead of the industrial Ethernet fieldbus technology, full-level data transmission, increases the synergy effect among the components in the automation system. The system adopts a modular and open architecture design with high scalability, provides automation systems ports which increase the flexibility and productivity of the machine tool.



High-precision and High-speed motorized spindle system with B-axis rotation within $\pm 90^\circ$ meets a wide processing range

The top performance motorized spindle system is particularly high-precision and high-speed, the max. speed of 18,000 rpm ensures high efficiency. The 4th axis processing differs from the conventional way of adding a rotary table, but is designed of the B-axis rotation within $\pm 90^\circ$, allows multi-angle processing of curved-surface materials, increases effectiveness of production and simplifies work of the operator, lets users enjoy a real flexible and yet dynamic machine experience.



Chain type chip conveyor



Disc type tool magazine



Machine bed

Wide range of processing option



ELECTRONICS



FURNITURE

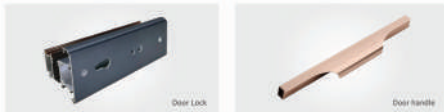

RAIL TRANSIT



OTHERS



CNC Vertical Machining Center

2 Linear Guide Way (MVL Series)

4 Linear Guide Way (LMV Series)

Vertical Machining Center High Speed
LMV/LV series

- High Speed LMV series (4 Linear Guide Way)
- High Speed Type
- APC series (2 Linear Guide Way)



LMV1600



LMV1200
BT40-BT50



LMV800APC



LMV-850
1000-BT40



MVL850

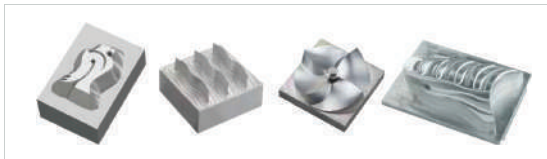
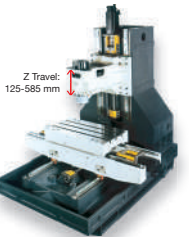
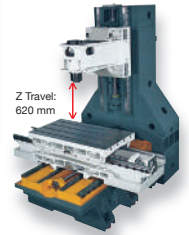

Model Dimension

	A	B	C	D	E	F	G
LV-50	2360	2764	/	1950	1999	471	/
LV-80	2360	2545	560	2149	1980	548	/
LV-100	2800	2545	702	2149	1988	565	/
LMV-760/800APC	2230	2707	1200	3282	2470	237	/
LMV-850	2565	2771	800-1200	2238	2099	672	/
LMV-1000	2810	2771	800-1200	2238	2099	672	/
LMV-1200	3220	2947	800-1200	2560	2168	779	/
LMV-1300	3650	2997	780	2507	2200	797	775
LMV-1600	4350	2997	800	2507	2200	797	775

MACHINE SPECIFICATIONS

	LMV1500 (Y=720)-A	LMV1500 (Y=825)-B	LMV1600	LMV1700	LMV1800	LMV2000	LMV800APC	
Table	Work Table: 1010x550 mm T-slot: 125x18 mm x 4T Max. Loading: 800 kg Three Axis Travel: 850x600x620 mm	1200x550 mm 100x18 mm x 5T 1000 kg 1000x600x620 mm	1300x680 mm 100x18 mm x 5T 1200 kg 1200x620x650 mm	650x430 mm 125x14 mm x 4T 250 kg 500x400x500mm	950x500 mm 80x18 mm x 5T 500 kg 800x500x500mm	1100x500 mm 80x18 mm x 5T 600 kg 1000x500x500mm	1550x700 mm 130x18 mm x 5T 1500 kg 1400x720 x 610mm(BT40) 1400x720x 680mm(BT50)	1550x700 mm 130x18 mm x 5T 1500 kg 150-760mm(BT40) 150-830mm(BT50)
Travel	Spindle Nose to Table Surface: 130-750 mm Spindle Center to Column Slide Ways: 620 mm	130-750 mm 620 mm	150-800mm 250-900mm	75-575mm 476mm	125-625mm 550mm	125-625mm 550mm	150-760mm(BT40) 150-830mm(BT50) 745mm	
Spindle	Spindle Taper: BT40 Spindle Diameter: Ø70 mm Spindle Speed: 8000 rpm 3 axis Slide Ways: Linear Way	BT40 Ø70 mm 8000 rpm Linear Way	BT40 Ø70 mm 8000 rpm X,Y: Linear Way / Z: Box Way	BT50 Ø100 mm 4500 rpm Linear Way	BT40 Ø60 mm 10000rpm(Belt) Linear Way	BT40 Ø70 mm 10000rpm(Belt) Linear Way	BT40/BT50 Ø70/Ø100 mm 8000rpm(BT40,belt) 6000rpm(BT50,belt) X,Y:Linear Way / Z:Box Way	
Feeds	3 axis Rapid Feeds: 30/30/30 m/min 3 axis Cutting Feeds: 10/10/10 m/min	30/30/30 m/min 10/10/10 m/min	X,Y: 24 m/min / Z: 18 m/min	10/10/10 m/min 48/48/36 m/min	10/10/10 m/min 36/36/36 m/min	10/10/10 m/min 36/36/36 m/min	30/30/20 m/min 10/10/10 m/min	
ATC	Tool Magazine type: Armless Tool Selection: Bi-direction shortest path	Armless Bi-direction shortest path	Armless Bi-direction shortest path	Arm type 12 T Bi-direction shortest path	Armless type20 T Bi-direction shortest path	Arm type20 T Bi-direction shortest path	Arm type24 T Bi-direction shortest path	
Motor	Max. Tool Diameter X Length: Ø100x300 mm Max. Tool Weight: 7 kg Tool Shank: BT40 ATC Capacity: 20T Spindle Motor(cont./30 min): 7.5/11 kw X/Y/Z axis Servomotor: HF204 X/Y/Z axis Ball Screw: Ø40xPitch 10 Coolant Pump: 660W	Ø100x300 mm 7 kg BT40 20T 7.5/11 kw HF204 Ø40xPitch 10 660W	Ø100x300 mm 7 kg BT40 20T 7.5/11 kw HF204 Ø50xPitch 12 660W	Ø146x300 mm 15kg BT40 20T 5.7/5KW HF354	Ø100 X 250 mm 7KG BT-40 5.7/5KW Ø32 660W	Ø100x250 mm 7KG BT-40 7.5/11KW 2.2/2.2/2.0 Kw Ø36 X Pitch12 660W	BT40:Ø80x350 mm BT50: Ø127x400 mm 7/15KG BT-40/BT50 15/18.5KW 3.5/3.5/3.5 Kw Ø36 X Pitch12 660W	BT40:Ø80x350 mm BT50: Ø127x400 mm 7/15KG BT-40/BT50 15/18.5KW 3.5/3.5/3.5 Kw Ø36 X Pitch12 660W
Miscellaneous	External Dimensions(L X W X H): 2565x2238x2771 mm N.W./G.W.(approx.): 6000/6700 kg Splash Guard: Fully Splash guard Coolant Tank Capacity: 240L	2810x2238x2771 mm 6200/6900 kg Fully Splash guard 250L	3220 x2560x2947 mm 7800/8800 kg Fully Splash guard 300L	3220x2560x2980 mm 8300/9300 kg Full Splash Guard 40*HQ(4 sets)	3000kg/3500kg Full Splash Guard 40*HQ(4 sets)	4500kg/5000kg Full Splash Guard 40*HQ(4 sets)	4700kg/5200kg Full Splash Guard 40*HQ(4 sets)	3690x3030x2585 (50) 3690x3030x2685 (50) 10000/11000 kg(40) 10500/11500 kg(50) Full Splash Guard 600L

Model	LV1500 (Y=720)-A	LV1500 (Y=825)-B	LV1600	LV1700	LV1800	LV2000	LMV800APC
Table	Work Table: 1500x720 mm T-slot: 130x18 mm x 5T Max. Loading: 1500kg	1700x700 mm 125x22 mm x 6T 1800kg	1700x800 mm 125x22 mm x 6T 2000kg	1900x800 mm 125x22 mm x 6T 2200kg	1900x800 mm 125x22 mm x 6T 2200kg	2100x800 mm 125x22 mm x 6T 2500kg	800x500mm x2pcs 100x18 mm x 5T 400 kg
Travel	Three Axis Travel: 1500x720x 610mm(BT40) 1500-830mm(BT50) Spindle Nose to Table Surface: 150-760mm(BT40) 150-830mm(BT50) Spindle Center to Column Slide Ways: 745mm	1500x720x 750mm(BT40) 1500-900mm 600rpm(BT50,belt) 6000rpm(BT50,belt)	1600x825x 750mm(BT40) 1600-900mm 600rpm(BT50,belt) 6000rpm(BT50,belt)	1700x825x 750mm(BT40) 1700-900mm 600rpm(BT50,belt) 6000rpm(BT50,belt)	1800x825x 750mm(BT40) 1800-900mm 600rpm(BT50,belt) 6000rpm(BT50,belt)	2000x825x 750mm(BT40) 2000-900mm 600rpm(BT50,belt) 6000rpm(BT50,belt)	800x460x450mm 150-600 mm 490 mm
Spindle	Spindle Taper: BT40/BT50 Spindle Diameter: Ø70/Ø100 mm Spindle Speed: 8000rpm(BT40,belt) 6000rpm(BT50,belt)	BT40/BT50 Ø70/Ø100 mm 6000rpm(BT40,belt) 6000rpm(BT50,belt)	BT40/BT50 Ø70/Ø100 mm 6000rpm(BT40,belt) 6000rpm(BT50,belt)	BT40/BT50 Ø70/Ø100 mm 6000rpm(BT40,belt) 6000rpm(BT50,belt)	BT40/BT50 Ø70/Ø100 mm 6000rpm(BT40,belt) 6000rpm(BT50,belt)	BT40/BT50 Ø70/Ø100 mm 6000rpm(BT40,belt) 6000rpm(BT50,belt)	BT40/BT50 Ø70 mm 10000 rpm
Feeds	3 axis Rapid Feeds: 30/30/20 m/min 3 axis Cutting Feeds: 10/10/10 m/min Tool Magazine type: Arm type24 T	24/24/18 m/min 10/10/10 m/min Arm type24 T	24/24/18 m/min 10/10/10 m/min Arm type24 T	24/24/18 m/min 10/10/10 m/min Arm type24 T	24/24/18 m/min 10/10/10 m/min Arm type24 T	24/24/18 m/min 10/10/10 m/min Arm type24 T	30/30/30 m/min 10/10/10 m/min Arm
ATC	Tool Selection: Bi-direction shortest path Max. Tool Diameter X Length: BT40: Ø80x350mm BT50: Ø127x400mm Max. Tool Weight: 7/16KG Tool Shank: BT40/BT50	Bi-direction shortest path BT40: Ø80x350mm BT50: Ø127x400mm 7/16KG BT40/BT50	Bi-direction shortest path BT40: Ø80x350mm BT50: Ø127x400mm 7/16KG BT40/BT50	Bi-direction shortest path BT40: Ø80x350mm BT50: Ø127x400mm 7/16KG BT40/BT50	Bi-direction shortest path BT40: Ø80x350mm BT50: Ø127x400mm 7/16KG BT40/BT50	Bi-direction shortest path BT40: Ø80x350mm BT50: Ø127x400mm 7/16KG BT40/BT50	Bi-direction shortest path Ø80x250mm 7 kg BT40
Motor	Spindle Motor(cont./30 min): 15/18.5KW X/Y/Z axis Servomotor: 3.5/3.5/3.5 Kw X/Y/Z axis Ball Screw: Ø50/50/40xPitch 10(40) Ø50/50/50xPitch 10(50)	15/18.5KW 4.5/4.5/4.5 Kw Ø50/50/40xPitch 10(40) Ø50/50/50xPitch 10(50)	15/18.5KW 4.5/4.5/4.5 Kw Ø50/50/40xPitch 10(40) Ø50/50/50xPitch 10(50)	15/18.5KW 4.5/4.5/4.5 Kw Ø50/50/40xPitch 10(40) Ø50/50/50xPitch 10(50)	15/18.5KW 4.5/4.5/4.5 Kw Ø50/50/40xPitch 10(40) Ø50/50/50xPitch 10(50)	15/18.5KW 4.5/4.5/4.5 Kw Ø50/50/40 X Pitch Ø50/50/50xPitch 10(50)	15/18.5KW 7.5/11 kw X,Y,HF224/Z:HF204B Ø32xPitch 12
Miscellaneous	External Dimensions(L X W X H): 3800x3030x2585(40) 3800x3030x2685(50) N.W./G.W.(approx.): 10500/11500 kg(40) 11000/12000 kg(50) Splash Guard: Full Splash Guard Coolant Tank Capacity: 600L	4250x3030x3100(40) 4250x3030x3200(50) 13500/15000 kg(40) 14000/15500 kg(50)	4350x3030x3100(40) 4350x3030x3200(50) 14000/15500 kg(40) 14500/16000 kg(50)	4450x3030x3100(40) 4450x3030x3200(50) 14500/16000 kg(40) 15000/16500 kg(50)	4550x3030x3100(40) 4550x3030x3200(50) 15000/17000 kg(40) 15500/17500 kg(50)	4800x3030x3100(40) 4800x3030x3200(50) 15500/17500 kg(40) 16000/18000 kg(50)	2230x3282x2707mm 5000/5500 kg Fully Splash guard 270L

BMV Series - 4 Box Way



BMV 2500



BMV 1200

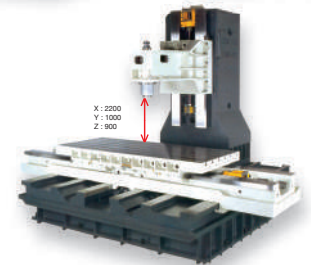
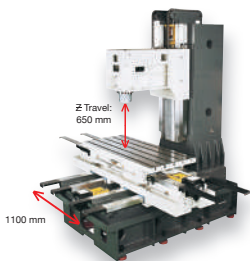

OPTION



Arm-type magazine
24-tool



Coolant through
spindle



High torque ZF
gear box

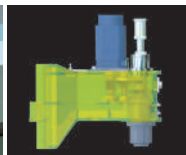

Gear head



Armless-type magazine 16
(BMV 850) 20-tool

MACHINE SPECIFICATIONS

Model		BMV850	BMV1000	BMV1200		BMV2200 Heavy Duty CNC Machining Center	BMV2500 Box Way Machining Center
Table	Work Table	1010x550mm	1200x550mm	1400x630mm		2400x1000mm	2700x1000mm
	T-slot	100x18 mmx5T	100x18 mmx5T	125x18 mmx5T		160x22 mmx6T	160x22 mmx6T
	Max. Loading	800 kg	1000 kg	1200 kg		3500 kg	3500 kg
Travel	3 axes travel	850x600x620	1000x600x620	1200x600 x650		2200x1100x900	2500x1100x900
	Spindle nose to table surface	130~750 mm	130~750 mm	150~800 mm(BT40)	250~900 mm(BT50)	240~1140 mm	240~1140 mm
	Spindle center to column slide ways	620mm	620mm	650mm		1050mm	1050mm
Spindle	Spindle taper	BT40	BT40	BT40/BT50		BT40/BT50	BT40/BT50
	Spindle diameter	Φ70 mm	Φ70 mm	Φ70/Φ100 mm		Φ70/Φ100 mm	Φ70/Φ100 mm
	Spindle speed	8000 rpm	8000 rpm	8000/4500 rpm		8000/4500 rpm	8000/4500 rpm
	3 axes slide ways	Box Way	Box Way	Box Way		Box Way	Box Way
Feedrate	3 axes rapid Feedrate	20 m/min	20 m/min	X,Y:20 m/min	Z:18 m/min	12/8/8 m/min	8/8/8 m/min
	3 axes cutting Feedrate	10 m/min	10 m/min	10 m/min		5 m/min	5 m/min
	Tool Magazine type	Armless	Armless	Armless		Chain-type	Chain-type
ATC	Tool selection	Bi-direction shortest path	Bi-direction shortest path	Bi-direction shortest path		Bi-direction shortest path	Bi-direction shortest path
	Max. Tool Diameter X Length	Φ100x300 mm	Φ100x300 mm	Φ100x300 mm	Φ146x300 mm	Φ127x300 mm	Φ127x300 mm
	Max. Tool Weight	7 kg	7 kg	7/15 kg		15 kg	15 kg
	Tool shank	BT40	BT40	BT40/BT50		BT50	BT50
	ATC Capacity	20T	20T	20T		32T	32T
Motor	Spindle Motor(cont./30 min)	7.5/11 kw	7.5/11 kw	7.5/11 kw /	11/15 kw	15/18.5 kw	15/18.5 kw
	X,Y,Z axis Servomotor	HF204	HF204	HF204	HF354	X:HF454/Y:HF703/Z:HF454SB	X:HF454/Y:HF703/Z:HF454SB
	X,Y,Z axis Ball Screw	Φ40xPitch 10	Φ40xPitch 10	Φ50xPitch 10		X,Z:Φ50xP10 mm	Y: Φ63xP10 mm
	Coolant Pump	660 W	660 W	660 W		750 W	750 W
	External Dimensions(LxWxH)	2550x2238x2650 mm	2810x2238x2650 mm	3220x2312x3022mm	3220x2215x3150mm	6216x3915x3461mm	6600x3919x3461mm
Miscellaneous	Packing Dimensions(LxWxH)	2870x2280x2550 mm	3130x2280x2550 mm	4700x2500x3500 mm		40"FR+40"HQ	40"FR+40"HQ
	N.W./G.W.(approx)	6000/6700 kg	6200/6900 kg	9000/10000 kg(BT40)	9500/10500 kg(BT50)	24000/26000 KG	26500/28500KG
	Splash Duard	Full Splash guard	Full Splash guard	Full Splash guard		Full Splash guard	Full Splash guard
	Coolant Tank Capacity	240L	250L	280L		560L	560L

Bed Type Milling Machine

VH Series (Vertical & Horizontal Head)



VH450



VH550



VH650B



JY-VH450



VH850

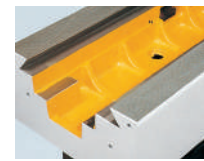

Rugged saddle



Practical telescopic cover



PC-Based controller (std)



Mitsubishi controller (opt)



Fanuc controller (opt)

MACHINE SPECIFICATIONS

Model		VH450	VH480 3 Axis Horizontal Milling Machine	VH550 CNC Bed Type Milling Machine	VH650B	VH780
Table	Table size	1500 X 450mm	1900 X 500mm	1900 X 500mm	2200 X 600mm	2600 X 700mm
	X/Y/Z 3 axes travel	1100/720/780mm	1300 X 850 X 780mm	1500 X 900 X 790mm	1700 X 1050 X 950mm	2000 X 1200 X 1000mm
	T-slot(size x number x distance)	18 X 5 X 80	18 X 5 X 80	18 X 5 X 80	20 X 5 X 125	20 X 5 X 125
	3 axes rapid feed rate	25-1500 (30-6000 PC-Based)	30-2800 (30-6000 PC-Based)	30-2800 (30-6000 PC-Based)	30-2800 (30-6000 PC-Based)	30-2800 (30-6000 PC-Based)
	3 axes cutting feed rate	1500(30-6000 PC-Based)	2800(30-600 PC-Based)	2800(30-600 PC-Based)	2800(30-6000 PC-Based)	2800(30-6000 PC-Based)
Cutting Range Reference	Cutting length	1100	1300	1300	1700	2000
	Cutting width	420	450	520	620	750
	Cutting height	500	500	520	640	750
	Loading weight	1000	1500	1500	2000	3000
	Cutting Range Reference	Spindle speed(60HZ)	45-1500 rpm variable	45-1500 rpm 18 Steps	45-1500 rpm 18 Steps	45-1500 rpm 18 Steps
Spindle taper		NT50	NT50	NT50	NT50	NT50
Spindle nose to table surface distance		0-617	0-583	0-603	0-753	0-810
Spindle center to slide way surface distance		450	480	550	650	780
Quill feedrate		NA	NA	NA	NA	NA
Turret head swivel angle		NA	NA	NA	NA	NA
horizontal spindle	Quill travel	NA	NA	NA	NA	NA
	Spindle speed(60HZ)	45-1500 rpm variable	45-1500 rpm 18 Steps	45-1500 rpm 18 Steps	45-1500 rpm 18 Steps	45-1500 rpm 18 Steps
	Spindle taper	NT50	NT50	NT50	NT50	NT50
	Spindle center to table surface distance	0-780	0-780	0-790	0-950	0-1000
	Spindle nose to table edge distance	190	305	280	335	400
Motor	Spindle motor	10HP X 4P AC	10HP X 4P AC	10HP X 4P AC	15HP X 4P AC	15HP X 4P AC
	X axis feeding motor	0.75KW	2.5KW	2.5KW	3KW	3KW
	Y axis feeding motor	0.75KW	2.5KW	2.5KW	3KW	3KW
	Z axis feeding motor	0.75KW	2.5KW	2.5KW	3KW	3KW
	Net weight	4200kg	5500kg	6000kg	7500kg	13500kg
Dimensions	Gross weight	5000kg (40"HQ)	6500kg (40"HQ)	7000kg (40"HQ)	8500kg (40"HQ)	15000kg (20"FR)
	Floor plan(L X W X H)	3500 X 3100 X 2750	4280 X 3780 X 2980	4500 X 3780 X 2980	5180 X 4080 X 3180	5880 X 4450 X 3180

Knee Type Milling Machine Series Specifications



JY-2HT

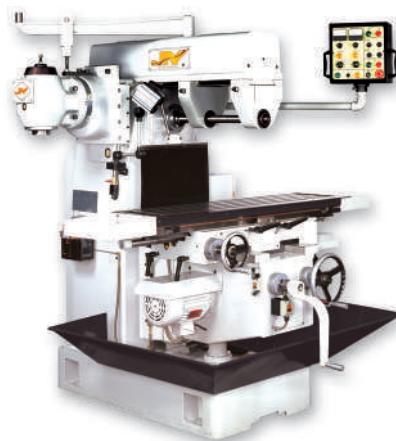

JY-2VH



JY-2T



JY-2VHT



KT-200S

MACHINE SPECIFICATIONS

Model	Unit	JY-15VS	JY-15SS	JY-15VC	JY-16VS	JY-16SS	JY-16VC	JY-18SS	JY-18VC	JY-860S	JY-860C	JY-20AS	JY-20AC	JY-20BS	JY-20BC	JY-26SHB	JY-26CHB	JY-28SHB	JY-28CHB		
Travel	Longitudinal travel (M/A)	mm	700/650 (Opt. 875/825)			850/750 (Opt. 950/850)			850/750 (Opt. 950/850)			860 (Opt. 1000)		750/700 (Opt. 850/800)		1000		1000		1000	
	Cross travel (M/A)	mm	360			426			426			400		440		420		400		400	
	Vertical travel (M/A)	mm	400			400			470			470		460		400		470		440	
	Slideway X/Y/Z	type	Δ / Δ / Δ			Δ / Δ / Δ			Δ / Δ / Δ			Δ / Δ / Δ		Δ / Δ / Δ		Δ / Δ / Δ		Δ / Δ / Δ		Δ / Δ / Δ	
	Quill travel	mm	127			127			140			140		140		140		140		140	
	Overarm travel	mm	457			457			540			540		570		570		700		700	
	Overarm swivel	degree	360			360			360			360		Fixed		Fixed		360		360	
	Quill swivel (R&L)/(F&B)	degree	±45/±45			±45/±45			±45/Fixed(Opt.±45)			±45/Fixed(Opt.±45)		±45/Fixed		±45/Fixed		±45/Fixed		±45/Fixed	
	Dist. from spindle nose to table	mm	50-450			50-450			90-560			20-490		100-560		100-500		100-570		100-540	
	Spindle centerline to column	mm	60-517			160-710			85-625			85-625		185-755		185-755		180-880		180-880	
Table	Dimension	mm	1067 x 230 (Opt. 1244 x 230)			1270 x 254 (Opt. 1270 x 254)			1270 x 254 (Opt. 1370 x 300)			1270 x 300 (Opt. 1370 x 300)		1270 x 254 (Opt. 1370 x 254)		1370 x 300		1370 x 300		1370 x 300	
	T-slots (Width x No. x Pitch)	mm	16 x 3 x 63			16 x 3 x 63			16 x 3 x 63			16 x 3 x 70		16 x 3 x 70		16 x 3 x 70		16 x 3 x 70		16 x 3 x 70	
	Max. table load	kg	200			200			200			300		200		300		300		300	
	Milling head	type	Variable	8/16 Steps	Inverter	Variable	8/16 Steps	Inverter	10/20 Steps	Inverter	10/20 Steps	Inverter	10 Steps	Inverter	10 Steps	Inverter	10/20 Steps	Inverter	10 Steps	Inverter	
Spindle	Speed	60Hz	rpm	80-2700(8)		80-2700(8)		70-3350(10)		70-3350(10)		75-3500		55-3600		75-3500		70-3350(10)		75-3500	
		50Hz	rpm	50-3500		55-3600		50-3500		55-3600		58-2780(10)		55-3600		60-2870		58-2780(10)		55-3600	
	Vertical feeds	mm/rev	0.04/0.08/0.15			0.04/0.08/0.15			0.04/0.08/0.15			0.04/0.08/0.15		0.04/0.08/0.15		0.04/0.08/0.15		0.04/0.08/0.15		0.04/0.08/0.15	
Motor	Taper	type	NT 30 or R8 (Opt. NT40)			NT 30 or R8 (Opt. NT40)			NT40			NT40		NT40		NT40		NT40		NT40	
	Quill Diameter	mm	85			85			105			105		110		110		105		110	
	Main spindle	HP	3	3	5	3	3	5	5	5	5	5	5	5	5	5	5	5	5	5	
Machine	Space(L x W x H)	mm	1800 x 2200 x 2150			2120 x 2550 x 2320			1920 x 2530 x 2420			1920 x 2860 x 2420		2250 x 2520 x 2420		2250 x 3100 x 2420		2270 x 3100 x 2520		2270 x 3100 x 2520	
	Packing dimension(L x W x H)	mm	1480 x 1600 x 1810			1660 x 1800 x 1910			1620 x 1830 x 1960			1620 x 2100 x 1960		1770 x 1870 x 2040		1770 x 2200 x 2040		1800 x 2200 x 2100		1800 x 2200 x 2100	
	Net Weight	kg	900			1100			1500			1700		1750		2000		2200		2250	
	Gross Weight	kg	1000			1200			1650			1800		1900		2150		2400		2450	

CNC Double Column Machining Center

SDV Series



Z-axis - 2 linear guide ways



SDV-3224

MACHINE SPECIFICATIONS

Item / Model	Unit	SDV-1611	SDV-2011	SDV-2215	SDV-3215	SDV-2219	SDV-3219	SDV-4219
X-Axis Travel	mm	2200	2040	2200	3200	2200	3200	4200
Y-Axis Travel	mm	1100	1100	1500	1500	1900	1900	1900
Z-Axis Travel	mm	760 (1000)	760 (1000)	760 (1000)	760 (1000)	760 (1000)	760 (1000)	760 (1000)
Table Size	mm	1600 x 1000	2000 x 1000	2000 x 1400	3000 x 1400	2000 x 1700	3000 x 1700	4000 x 1700
T-Slots Dimension	mm	22 (24, 28)	22 (24, 28)	22 (24, 28)	22 (24, 28)	22 (24, 28)	22 (24, 28)	22 (24, 28)
Table Load Capacity	kgs	3000	3500	5000	7000	5000	8000	12000
Distance between Two Columns	mm	1200	1200	1600	1600	2000	2000	2000
Distance from Spindle Nose to Table	mm	250 - 1010 (250 - 1250) 355 - 1115 (355 - 1355)	250 - 1010 (250 - 1250) 355 - 1115 (355 - 1355)	250 - 1010 (250 - 1250) 355 - 1115 (355 - 1355)	250 - 1010 (250 - 1250) 355 - 1115 (355 - 1355)	250 - 1010 (250 - 1250) 355 - 1115 (355 - 1355)	250 - 1010 (250 - 1250) 355 - 1115 (355 - 1355)	250 - 1010 (250 - 1250) 355 - 1115 (355 - 1355)
Spindle Taper, Tool Shank		ISO NO.50(40) BT-50, CAT-50, DIN 69871 (BT-40, CAT-40)		ISO NO.50(40) BT-50, CAT-50, DIN 69871 (BT-40, CAT-40)		ISO NO.50(40) BT-50, CAT-50, DIN 69871 (BT-40, CAT-40)		
Spindle Speed Range	rpm	20 - 4000 (30 - 6000) (100 - 10000) (80 - 8000)		20 - 4000 (30 - 6000) (100 - 10000) (80 - 8000)		20 - 4000 (30 - 6000) (100 - 10000) (80 - 8000)		
Main Motor Output (30 min Rating/Cont)	HP	25 / 20 (30 / 25)		25 / 20 (30 / 25) (35 / 30)		25 / 20 (30 / 25) (35 / 30)		
Rapid Traverse Rate X,Y Axis	mm/min	15000 (20000)		12000 (15000)		12000 (15000)		10000 (12000)
Rapid Traverse Rate Z Axis	mm/min	12000 (15000)		12000 (15000)		12000 (15000)		10000 (12000)
Cutting Feed Rate	mm/min	1 - 5000 (1 - 8000)		1 - 5000 (1 - 8000)		1 - 5000 (1 - 8000)		1 - 5000 (1 - 8000)
Minimum Input Increment	mm/min	0.001		0.001		0.001		0.001
Tool Magazine Capacity	pcs	(16 / 20 / 32 / 40)		(16 / 20 / 32 / 40)		(16 / 20 / 32 / 40)		(16 / 20 / 32 / 40 / 60)
Max. Tool Diameter / Adjacent Pockets Empty	mm	Ø 125 / Ø 210		Ø 125 / Ø 210		Ø 125 / Ø 210		Ø 125 / Ø 210
Max. Tool Length (from Gauge Line)	mm	350		350		350		350
Max. Tool Weight	kgs	(18 / 20)		(18 / 20)		(18 / 20)		(18 / 20)
Tool selection Method		(ABS, Random Bi)		(ABS, Random Bi)		(ABS, Random Bi)		(ABS, Random Bi)
Tool Change Time(T-T) (approx)	secs	8 (4.5)		8 (4.5)		8 (4.5)		8 (4.5)
Power Requirement	Kva	40 (45)		40 (45)		40 (45)		50 (55)
Floor Space Requirement	center	7200x4800	8000x4800	8100x5200	10100x5200	8200x6500	10700x6500	13000x6500
Machine Height from Floor Level	mm	4350	4350	4350 / 4870	4350 / 4870	4240 / 4760	4240 / 4760	4240 / 4760
Machine Weight(approx)	kgs	18500	19000	21000	24500	22000	29000	34000
CNC Controller		Fanuc, Meltas, Siemens, Heidenhain Series etc.		Fanuc, Meltas, Siemens, Heidenhain Series etc.		Fanuc, Meltas, Siemens, Heidenhain Series etc.		
Positioning Accuracy	mm	JIS B6338 0.01 / 300, VDI3441 P0.025		JIS B6338 0.01 / 300, VDI3441 P0.025		JIS B6338 0.01/300, VDI 3441 P0.025		JIS B6338 0.01/300, VDI 3441 P0.035
Repeatability Accuracy	mm	± 0.003		± 0.003		± 0.003		± 0.005

Item / Model	Unit	SDV-1611H	SDV-2011H	SDV-2215H	SDV-3215H	SDV-2219H	SDV-3219H	SDV-4219H
X-Axis Travel	mm	1600	2040	2200	3200	2200	3200	4200
Y-Axis Travel	mm	1100	1100	1500	1500	1900	1900	1900
Z-Axis Travel	mm	760	760	760 (1000)	760 (1000)	760 (1000)	760 (1000)	760 (1000)(1200)(1400)
Table Size	mm	1600 x 1000	2000 x 1000	2000 x 1400	3000 x 1400	2000 x 1700	3000 x 1700	4000 x 1700
T-Slots Dimension	mm	22 (24, 28)	22 (24, 28)	22 (24, 28)	22 (24, 28)	22 (24, 28)	22 (24, 28)	22 (24, 28)
Table Load Capacity	kgs	3000	3500	5000	7000	5000	8000	12000
Distance between Two Columns	mm	1200	1200	1600	1600	2000	2000	2000
Distance from Spindle Nose to Table	mm	250 - 1010	250 - 1010	165 - 925 / 270 - 1030 165 - 1165 / 270 - 1270	165 - 925 / 270 - 1030 165 - 1165 / 270 - 1270	165 - 925 / 270 - 1030 165 - 1165 / 270 - 1270	165 - 925 / 270 - 1030 165 - 1165 / 270 - 1270	165 - 925 / 270 - 1030 165 - 1165 / 270 - 1270 165 - 1365 / 270 - 1470 165 - 1565 / 270 - 1670
Spindle Taper, Tool Shank		ISO NO.50(40) BT-50, CAT-50, DIN 69871 (BT-40, CAT-40), HSK-A63, HSK-A100		ISO NO.50(40) BT-50, CAT-50, DIN 69871 (BT-40, CAT-40), HSK-A63, HSK-A100		ISO NO.50(40) BT-50, CAT-50, DIN 69871 (BT-40, CAT-40), HSK-A63, HSK-A100		
Spindle Speed Range	rpm	20 - 4000 (30 - 6000) (100 - 10000) (80 - 8000) (12000 - 24000)		20 - 4000 (30 - 6000) (100 - 10000) (80 - 8000) (12000 - 24000)		20 - 4000 (30 - 6000) (100 - 10000) (80 - 8000) (12000 - 24000)		
Main Motor Output (30 min Rating/Cont)	HP	30 / 25 (35 / 30)		30 / 25 (35 / 30)		30 / 25 (35 / 30)		30 / 25 (35 / 30)
Rapid Traverse Rate X,Y Axis	mm/min	15000 (20000)		12000 (15000)		12000 (15000)		10000 (12000)
Rapid Traverse Rate Z Axis	mm/min	12000 (15000)		12000 (15000)		12000 (15000)		10000 (12000)
Cutting Feed Rate	mm/min	1 - 5000 (1 - 8000)		1 - 5000 (1 - 8000)		1 - 5000 (1 - 8000)		1 - 5000 (1 - 8000)
Minimum Input Increment	mm/min	0.001		0.001		0.001		0.001
Tool Magazine Capacity	pcs	(20 / 32 / 40)		(20 / 32 / 40)		(20 / 32 / 40)		(20 / 32 / 40 / 60)
Max. Tool Diameter / Adjacent Pockets Empty	mm	Ø 125 / Ø 210		Ø 125 / Ø 210		Ø 125 / Ø 210		Ø 125 / Ø 210
Max. Tool Length (from Gauge Line)	mm	350		350		350		350
Max. Tool Weight	kgs	(18 / 20)		(18 / 20)		(18 / 20)		(18 / 20)
Tool selection Method		(ABS, Random Bi)		(ABS, Random Bi)		(ABS, Random Bi)		(ABS, Random Bi)
Tool Change Time(T-T)(approx)	secs	8 (4.5)		8 (4.5)		8 (4.5)		8 (4.5)
Power Requirement	Kva	40 (45)		40 (45)		40 (45)		50 (55)
Floor Space Requirement	mm	7200x4800	8000x4800	8000x6100	10000x6100	8300x6500	10700x6500	13000x6500
Machine Height from Floor Level	mm	4355	4355	4250 / 4830	4250 / 4830	4250 / 4830	4250 / 4830	4250 / 4830 / 5510 / 6110
Machine Weight(approx)	kgs	20000	20500	23500	27000	25500	31500	36500
CNC Controller		Fanuc, Meltas, Siemens, Heidenhain series etc.		Fanuc, Meltas, Siemens, Heidenhain series etc.		Fanuc, Meltas, Siemens, Heidenhain series etc.		
Positioning Accuracy	mm	JIS B6338 0.01/300, VDI 3441 P0.025		JIS B6338 0.01/300, VDI 3441 P0.025		JIS B6338 0.01/300, VDI 3441 P0.025		JIS B6338 0.01/300, VDI 3441 P0.035
Repeatability Accuracy	mm	± 0.003		± 0.003		± 0.003		± 0.005

CNC Double Column Machining Center

SDV-H series

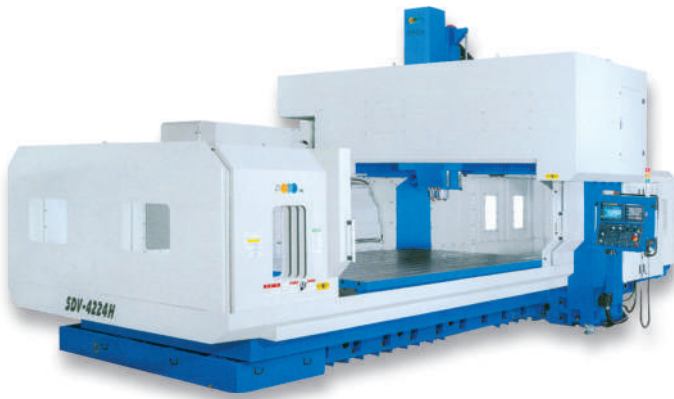

SDV-4224H



SDV-2215H

SDV-3224	SDV-4224	SDV-5224	SDV-6224	SDV-3229	SDV-4229	SDV-5229	SDV-6229	SDV-4234	SDV-5234	SDV-6234	SDV-4239	SDV-5239	SDV-6239
3200	4200	5200	6200	3200	4200	5200	6200	4200	5200	6200	4200	5200	6200
2400	2900	2400	2400		2900			2900	3400			3900	
	760 (1000)				760 (1000)				760 (1000)			760 (1000)	
3000 x 2200	4000 x 2700	5000 x 2200	6000 x 2200	3000 x 2700	5000 x 2700	5000 x 2200	6000 x 2700	4000 x 2700	5000 x 3200	6000 x 3200	4000 x 3700	5000 x 3700	6000 x 3700
	22 (24, 28)				22 (24, 28)			22 (24, 28)	22 (24, 28)		22 (24, 28)		
10000	17000	17500	25000	12500	20000	17500	27500	17000	22500	30000	21000	25000	32500
2500	3000	2500	2500	3000	3000	2500	3000	3000	3500	3500		4000	
	250 - 1010 (250 - 1250)				250 - 1010 (250 - 1250)				250 - 1010 (250 - 1250)			250 - 1010 (250 - 1250)	
	145 - 905 (145 - 1145)				145 - 905 (145 - 1145)				145 - 905 (145 - 1145)			145 - 905 (145 - 1145)	
	ISO NO.50(40) BT-50, CAT-50, DIN 69871 (BT-40, CAT-40)				ISO NO.50(40) BT-50, CAT-50, DIN 69871 (BT-40, CAT-40)				ISO NO.50(40) BT-50, CAT-50, DIN 69871 (BT-40, CAT-40)			ISO NO.50(40) BT-50, CAT-50, DIN 69871 (BT-40, CAT-40)	
	20 - 4000 (30 - 6000) (100 - 10000) (80 - 8000)				20 - 4000 (30 - 6000) (100 - 10000) (80 - 8000)				20 - 4000 (30 - 6000) (100 - 10000) (80 - 8000)			20 - 4000 (30 - 6000) (100 - 10000) (80 - 8000)	
	25 / 20 (30 / 25) (35 / 30)				25 / 20 (30 / 25) (35 / 30)				25 / 20 (30 / 25) (35 / 30)			25 / 20 (30 / 25) (35 / 30)	
	10000 (12000)				10000 (12000)				10000 (12000)			10000 (12000)	
	12000 (15000)				12000 (15000)				12000 (15000)			12000 (15000)	
	1 - 5000 (1 - 8000)				1 - 5000 (1 - 8000)				1 - 5000 (1 - 8000)			1 - 5000 (1 - 8000)	
	0.001				0.001				0.001			0.001	
	(16 / 20 / 32 / 40 / 60)				(16 / 20 / 32 / 40 / 60)				(16 / 20 / 32 / 40 / 60)			(16 / 20 / 32 / 40 / 60)	
	Ø125 / Ø 210				Ø125 / Ø 210				Ø125 / Ø 210			Ø125 / Ø 210	
	350				350				350			350	
	(18 / 20)				(18 / 20)				(18 / 20)			(18 / 20)	
	(ABS, Random Bi)				(ABS, Random Bi)				(ABS, Random Bi)			(ABS, Random Bi)	
	8 (4.5)				8 (4.5)				8 (4.5)			8 (4.5)	
45 (50)	50 (55)	55 (60)		45 (50)	50 (55)	55 (60)	60 (65)	55 (60)	60 (65)		55 (60)	60 (65)	
10700x7000	13000x7000	15000x7000	17300x7000	10700x7500	13000x7500	15000x7500	17300x7500	13000x8000	15000x8000	17300x8000	13000x8500	15000x8500	17300x8500
4240 / 4760				4240 / 4760				4240 / 4760			4240 / 4760		
32500	37000	55000	69000	35000	40000	58500	72000	43000	62000	75000	46000	65000	78000
	Fanuc, Meldas, Siemens, Heidenhain Series etc.				Fanuc, Meldas, Siemens, Heidenhain Series etc.				Fanuc, Meldas, Siemens, Heidenhain Series etc.			Fanuc, Meldas, Siemens, Heidenhain Series etc.	
JIS B6338 0.01/300 , VDI 3441 P0.025	JIS B6338 0.01/300 , VDI 3441 P0.035			JIS B6338 0.01/300 , VDI 3441 P0.035				JIS B6338 0.01/300 , VDI 3441 P0.035			JIS B6338 0.01/300 , VDI 3441 P0.035		JIS B6338 0.01/300 , VDI 3441 P0.035
	±0.005				±0.005				±0.005			±0.005	

SDV-3224H	SDV-4224H	SDV-5224H	SDV-6224H	SDV-3229H	SDV-4229H	SDV-5229H	SDV-6229H	SDV-4234H	SDV-5234H	SDV-6234H	SDV-4239H	SDV-5239H	SDV-6239H
3200	4200	5200	6200	3200	4200	5200	6200	4200	5200	6200	4200	5200	6200
	2400				2900			3400				3900	
	760 (1000)(1200)(1400)				760 (1000)(1200)(1400)			760 (1000)(1200)(1400)				760 (1000)(1200)(1400)	
3000 x 2200	4000 x 2200	5000 x 2200	6000 x 2200	3000 x 2700	4000 x 2700	5000 x 2700	6000 x 2700	4000 x 3200	5000 x 3200	6000 x 3200	4000 x 3700	5000 x 3700	6000 x 3700
	22 (24, 28)				22 (24, 28)			22 (24, 28)	22 (24, 28)		22 (24, 28)		
10000	15000	17500	25000	12500	17000	20000	27500	19000	22500	30000	21000	25000	32500
	2500				3000				3500			4000	
	165 - 925 / 270 - 1030				165 - 925 / 270 - 1030				165 - 925 / 270 - 1030			165 - 925 / 270 - 1030	
	165 - 1165 / 270 - 1270				165 - 1165 / 270 - 1270				165 - 1165 / 270 - 1270			165 - 1165 / 270 - 1270	
	165 - 1365 / 270 - 1470				165 - 1365 / 270 - 1470				165 - 1365 / 270 - 1470			165 - 1365 / 270 - 1470	
	165 - 1565 / 270 - 1670				165 - 1565 / 270 - 1670				165 - 1565 / 270 - 1670			165 - 1565 / 270 - 1670	
	ISO NO.50(40) BT-50, CAT-50				ISO NO.50(40) BT-50, CAT-50				ISO NO.50(40) BT-50, CAT-50, DIN 69871 (BT-40, CAT-40), HSK-A63, HSK-A100			ISO NO.50(40) BT-50, CAT-50, DIN 69871 (BT-40, CAT-40), HSK-A63, HSK-A100	
	DIN 69871 (BT-40, CAT-40), HSK-A63, HSK-A100				DIN 69871 (BT-40, CAT-40), HSK-A63, HSK-A100				20 - 4000 (30 - 6000) (100 - 10000) (80 - 8000) (12000 - 24000)			20 - 4000 (30 - 6000) (100 - 10000) (80 - 8000) (12000 - 24000)	
	30 / 25 (35 / 30)				30 / 25 (35 / 30)				30 / 25 (35 / 30)			30 / 25 (35 / 30)	
	10000 (12000)				10000 (12000)				10000 (12000)			10000 (12000)	
	12000 (15000)				12000 (15000)				12000 (15000)			12000 (15000)	
	1 - 5000 (1 - 8000)				1 - 5000 (1 - 8000)				1 - 5000 (1 - 8000)			1 - 5000 (1 - 8000)	
	0.001				0.001				0.001			0.001	
	(20 / 32 / 40 / 60)				(20 / 32 / 40 / 60)				(20 / 32 / 40 / 60)			(20 / 32 / 40 / 60)	
	Ø125 / Ø 210				Ø125 / Ø 210				Ø125 / Ø 210			Ø125 / Ø 210	
	350				350				350			350	
	(18 / 20)				(18 / 20)				(18 / 20)			(18 / 20)	
	(ABS, Random Bi)				(ABS, Random Bi)				(ABS, Random Bi)			(ABS, Random Bi)	
	8 (4.5)				8 (4.5)				8 (4.5)			8 (4.5)	
45 (50)	50 (55)	55 (60)		45 (50)	50 (55)	55 (60)	60 (65)	55 (60)	60 (65)		55 (60)	60 (65)	
10700x6500	13000x7000	15000x7000	17300x7000	10700x7500	13000x7500	15000x7500	17300x7500	13000x8000	15000x8000	17300x8000	13000x8500	15000x8500	17300x8500
4250 / 4830	4250 / 4830 / 5510 / 6110			4250 / 4830 / 5510 / 6110				4250 / 4830 / 5510 / 6110			4250 / 4830 / 5510 / 6110		
31500	39500	57500	71500	36000	42500	61000	74500	45500	64500	77500	48500	67500	80500
	Fanuc, Meldas, Siemens, Heidenhain series etc.				Fanuc, Meldas, Siemens, Heidenhain series etc.				Fanuc, Meldas, Siemens, Heidenhain series etc.			Fanuc, Meldas, Siemens, Heidenhain series etc.	
JIS B6338 0.01/300 , VDI 3441 P0.035	JIS B6338 0.01/300 , VDI 3441 P0.035			JIS B6338 0.01/300 , VDI 3441 P0.035				JIS B6338 0.01/300 , VDI 3441 P0.035			JIS B6338 0.01/300 , VDI 3441 P0.035		JIS B6338 0.01/300 , VDI 3441 P0.035
	±0.005				±0.005				±0.005			±0.005	

CNC Lathe



CHL-2140 / 2160 / 2180 / 21120

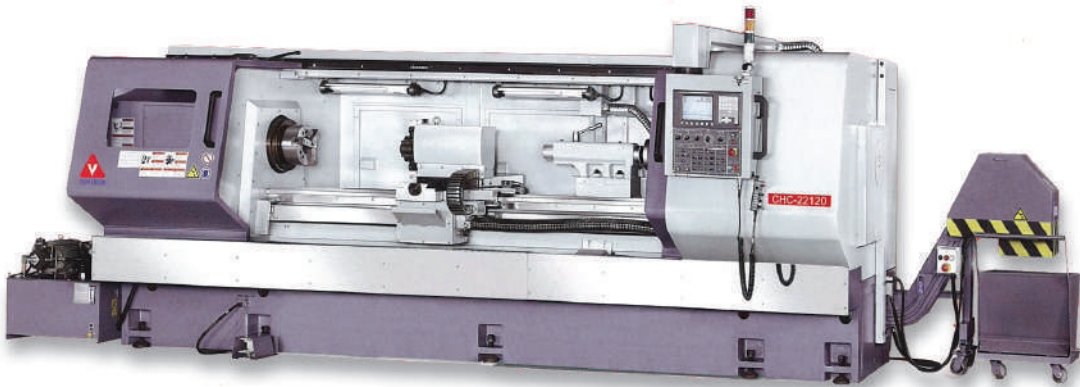

CHC-2240 / 2260 / 2280 / 22120

MACHINE SPECIFICATIONS

MODEL		CHL-2140	CHL-2160	CHL-2180	CHL-21120	CHC-2240	CHC-2260	CHC-2280	CHC-22120
Capacity	No. of control axis	2 axis				2 axis			
	Swing over bed	Ø533mm (20.98")				Ø550mm (21.653")			
	STD. D1-8 distance between centers	845mm(33.27")	1345mm(52.95")	1845mm(72.64")	2845mm(112.0")	870mm(34.25")	1370mm(53.93")	1870mm(73.62")	2870mm(113.0")
	4 way tool post	620mm(24.41")	1120mm(44.09")	1620mm(63.78")	2620mm(103.1")	680mm(26.77")	1180mm(46.45")	1680mm(66.14")	2680mm(105.5")
	STD. D1-8 Max. working length	530mm(20.87")	1030mm(40.55")	1530mm(60.24")	2530mm(99.61")	590mm(23.22")	1090mm(42.91")	1590mm(62.60")	2590mm(102.0")
	Hyd. VDI disc	490mm(19.29")	990mm(38.98")	1490mm(58.66")	2490mm(98.03")	550mm(21.65")	1050mm(41.33")	1550mm(61.02")	2550mm(100.4")
Headstock and Main Spindle	Max. working diameter	Ø305mm (12")				Ø325mm (12.8")			
	width of bed	345mm (13.58")				345mm (13.58")			
	Spindle nose, internal taper	STD. D1-8 OPT. A2-8, Ø85mm Taper 1/19.18				ASA A2-8, Ø97mm Taper 1/20			
	Spindle center sleeve	Ø85mm Taper 1/19.18 x MT.No.5				Ø91mm(3.582") / Ø78mm(3.07")			
	Spindle bore	Ø80 mm (3.149")				Ø91mm(3.582") / Ø78mm(3.07")			
	Spindle speed : Gear steps /Range	M code automatic 4 steps/	M41 20~60 R.P.M M42 61~200 R.P.M M43 201~670 R.P.M M44 671~2000 R.P.M	Infinitely variable		35~3500 R.P.M Infinitely variable			
Cross Slide (X-axis) and Carriage (Z-axis)	Cross slide travel (X-axis) STD.	300 mm (11.8")				300mm(11.8")			
	Longitudinal travel (Z-axis) STD.	720 mm (28.3")	1220 mm (48.0")	1720 mm (67.7")	2720 mm (107.1")	780mm(30.7")	1280mm (50.4")	1780mm(70.1")	2780mm(109.4")
	AC servomotor (X-axis)	1.3 kW 8.34 N.m ~ FANUC B12 / 3000is				1.8kW 11 N.m ~ FANUC S12 / 3000is			
	AC servomotor (Z-axis)	2.9 kW 18.6 N.m ~ FANUC B22 / 2000is				2.5kW 20 N.m ~ FANUC S22 / 2000is			
	Dia. of ball screw (X-axis)	Ø25 mm (0.98") P5 C5				Ø25mm(0.98") P5 C5			
	Dia. of ball screw (Z-axis)	Ø50 mm (1.97") P10 C5		Ø63 mm (2.48") P10 C5		Ø50mm(1.97") P10 C5		Ø63mm (2.48") P10 C5	
Turret	Rapid traverse speed (X-axis)	7.5 m/min (295 ipm)				7.5m/min (295 ipm)			
	Rapid traverse speed (Z-axis)	10 m/min (394 ipm)				10m/min (394 ipm)			
	Tool station	STD. Manual 4 way tool post		OPT. Hyd. VDI. V8 or Hydraulic P8		STD. Manual 4 way tool post		OPT. Hyd. VDI.V8 or Hydraulic P8	
	Size of external turning tool	□25 mm		□25 mm		□25 mm		□25 mm	
	Boring bar diameter	Ø40 mm (1.575")		Ø32 mm (1.26")		Ø40mm(1.575")		Ø32mm(1.26")	
	Tailstock	Quill diameter	Ø85mm (3.346")				Ø85mm(3.346")		
Quill travel		178 mm (7")				178mm(7")			
Taper of center		MT.No.5				MT.No.5			
Motor	Main spindle continuous rated (30 min. rated)	AC 9kW (12 HP) Wide range heavy duty FANUC AC spindle motor				AC 9 kw (12HP) Wide range heavy duty Fanuc AC spindle motor			
	Hydraulic oil pump	AC 11kW (15 HP) MODEL B1lp18/6000				AC 11kw (15HP) MODEL slip18/6000			
	Forced lubrication for headstock	OPT. 0.75 kW (1HP) OPT. 1.5 kW (2HP)				STD. 0.75kW (1 HP) OPT. 1.5kW (2 HP)			
	Automatic gears shift	1/4 HP				1/6HP			
	Coolant pump	60 W				1/6HP			
Tank Capacity	Hydraulic tank	STD. 25 Litre (5.5 gal.)		OPT. 40 Litre (8.8 gal.)		STD. 25 Litre (5.5 gal.) OPT. 40 Litre (8.8 gal.)			
	Coolant tank	60L(13.2 gal.)	120L(26.4 gal.)	180L(39.6 gal.)	240L(52.8 gal.)	60L(13.2 gal.)	120L(26.4 gal.)	180L(39.6 gal.)	240L(52.8 gal.)
Measurements	Weight (Net / Gross) Approx.	4,050kgs / 4,450kgs	4,400kgs / 4,900kgs	4,800kgs / 5,400kgs	5,300kgs / 6,000kgs	4,050kgs / 4,450kgs	4,400kgs / 4,900kgs	4,800kgs / 5,400kgs	5,300kgs / 6,000kgs
	Packing sizes Length	3200 mm (126")	3700 mm (145.7")	4200 mm (165.4")	5200 mm (204.7")	3200 mm (126")	3700 mm (145.7")	4200 mm (165.4")	5200 mm (204.7")
	Width x Height	Width 2300 mm (90.6") x Height 2240 mm (88.2")				Width 2300 mm (90.6") x Height 2230 mm (87.8")			

High Speed Precision Lathe

Ø 80 MM SPINDLE BORE

ML Series

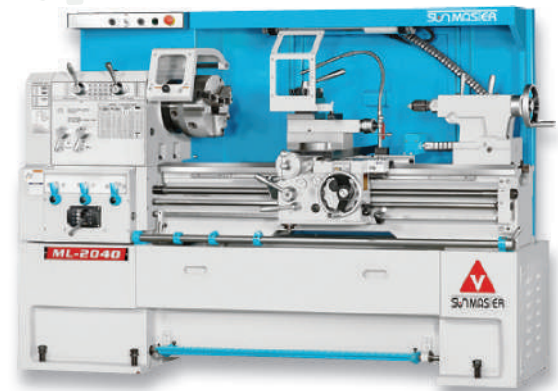
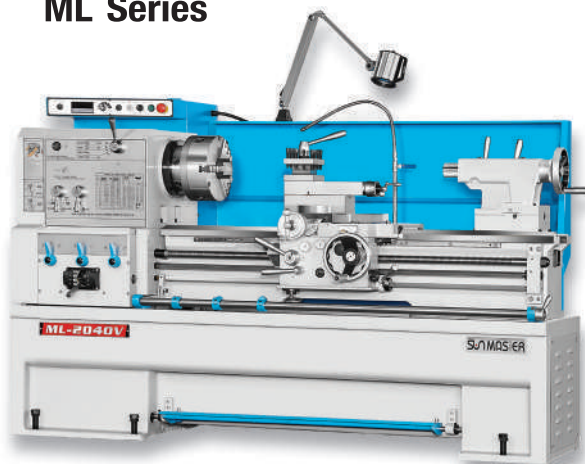

ML -1740/1760/1780
-2040/2060/2080

ML -1740V/1760V/1780V
-2040V/2060V/2080V

SAFETY FEATURES

Nylon safety gears in end train.
Shear pin in leadscrew.



HEAVY DUTY SPINDLE

- Proven design on same models but with big spindle bore (80 mm) offering more efficient, durable operation.
- Spindle is made from forged alloy steel, hardened, ground & heat treated for dynamical balance.
- The spindle is supported at three points by high precision taper roller and ball bearings keeping rigidity and accuracy.



CARRIAGE & SLIDE

- Anti-Float design backlash eliminator fitted in cross slide nut.
- Safety clutch at feed shaft.
- One shot lubrication in carriage & top slide.
- Dual dials supply inch system screw.
- Metric dial supply metric system only.

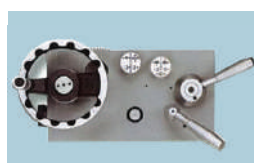

APRON

- R/H or L/H wheel available upon request.
- Integrated automatic control for longitudinal, cross, forward and reverse feed.



HEADSTOCK

- Housing is vibration resistance, deflection-free.
- Gears are hardened & MAAG or REISHAUER ground.

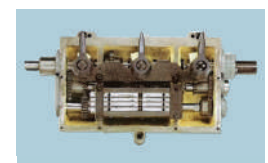

GEAR BOX

Universal gear box allows inch or metric dial. Turing M.P., D.P. threads without gear change.

MACHINE SPECIFICATIONS

MODEL		ML-1740	ML-1760	ML-1780	ML-2040	ML-2060	ML-2080	ML-1740V	ML-1760V	ML-1780V	ML-2040V	ML-2060V	ML-2080V
Capacity	Height of centers	216 mm (8.5")			254 mm (10")			216 mm (8.5")			254 mm (10")		
	Swing over bed	Ø432 mm (17")			Ø508 mm (20")			Ø432 mm (17")			Ø508 mm (20")		
	Swing in gap	Ø622 mm (24.48")			Ø698 mm (27.48")			Ø622 mm (24.48")			Ø698 mm (27.48")		
	Swing over cross slide	Ø277 mm (10.9")			Ø353 mm (13.89")			Ø277 mm (10.9")			Ø353 mm (13.89")		
	Distance between centers	1000 mm (40")	1500 mm (60")	2200 mm (86.5")	1000 mm (40")	1500 mm (60")	2200 mm (86.5")	1000 mm (40")	1500 mm (60")	2200 mm (86.5")	1000 mm (40")	1500 mm (60")	2200 mm (86.5")
Headstock and Main Spindle	Width of bed	305 mm (12")											
	Gap width in front of faceplate	195 mm (7.67")											
	Spindle nose, internal taper	D1-6, Ø85 mm Taper 1/19.18											
	Spindle center sleeve	Ø85 mm Taper 1/19.18 x MT. No.5											
	Spindle bore	Ø80 mm (3.149")											
Carriage	Spindle speed:	12 steps / 36 ~ 1800 R.P.M.						L 30 ~ 125 rpm					
	Gear steps / Range	A 36	50	70	105	M 125 ~ 450 rpm							
		B 130	180	250	380	H 450 ~ 2200 rpm							
		C 620	900	1200	1800	Infinitely variable							
Threads and Feeds	Cross slide travel	235 mm (9.25")			272 mm (10.7")			235 mm (9.25")			272 mm (10.7")		
	Top slide travel	156 mm (6.1")											
	Whitworth threads: Kinds / Range	45 Kinds / 2~72 T.P.I.											
	Metric threads: Kinds / Range	39 Kinds / 0.2~14 mm											
	D.P. threads: Kinds / Range	21 Kinds / 8~44 D.P.											
Tailstock	M.P. threads: Kinds / Range	18 Kinds / 0.3~3.5 M.P.											
	Longitudinal feed	0.04~1.0 mm (0.0015"~0.04")											
	Cross feed	0.02~0.5 mm (0.00075"~0.02")											
	Quill diameter	Ø59 mm (2.322")											
Motor	Quill travel	127 mm (5")											
	Taper of center	MT.No.4											
	Main spindle	7.5HP						AC 5.5 kw (7.5HP), Inverter					
Measurement	Forced lubrication for headstock							1/4 HP					
	Coolant pump	1/8HP											
	Weight approx.	Net (kgs)	1700	1850	2375	1750	1900	2425	1700	1850	2375	1750	1900
Packing sizes	Gross (kgs)	1900	2100	2675	1950	2150	2725	1900	2100	2675	1950	2150	2725
	Length	2400 mm (94.5") / 2900 mm (114.2") / 3700 mm (145.7")											
	WidthxHeight	Width 1155 mm (45.5") x Height 1900 mm (74.8")											

V : Variable

High Speed Precision Lathe

TC Series

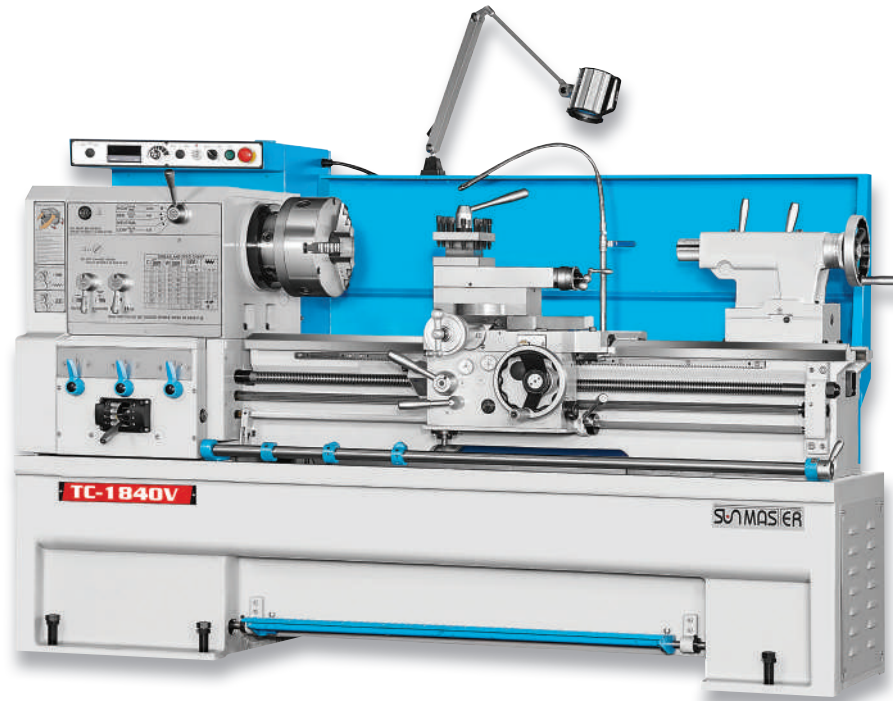

TC-1840V

MACHINE SPECIFICATIONS

MODEL		TC-1640	TC-1660	TC-1840	TC-1860	TC-1640V	TC-1660V	TC-1840V	TC-1860V	
Capacity	Height of centers	205 mm (8.07")		231 mm (9.09")		205 mm (8.07")		231 mm (9.09")		
	Swing over bed	Ø410 mm (16.14")		Ø462 mm (18.18")		Ø410 mm (16.14")		Ø462 mm (18.18")		
	Swing in gap	Ø620 mm (24.4")		Ø652 mm (25.66")		Ø620 mm (24.4")		Ø652 mm (25.66")		
	Swing over cross slide	Ø255 mm (10.04")		Ø305 mm (12")		Ø255 mm (10.04")		Ø305 mm (12")		
	Distance between centers	1000 mm (40")	1500 mm (60")	1000 mm (40")	1500 mm (60")	1000 mm (40")	1500 mm (60")	1000 mm (40")	1500 mm (60")	
Headstock and Main Spindle	Width of bed	305 mm (12")				305 mm (12")				
	Gap width in front faceplate	120 mm (4.72")				120 mm (4.72")				
	Spindle nose	D1-6 (std) / A2-6 (opt)				D1-6 (std) / A2-6 (opt)				
	Spindle center sleeve	Ø70 mm (2.76") Taper 1/19.18 MT x NO.4				Ø70 mm (2.76") Taper 1/19.18 MT x NO.4				
	Spindle bore	Ø65 mm (2.55")				Ø65 mm (2.55")				
Carriage	Spindle speed:	12 steps / 36 ~ 1800 RPM				3 steps / 30 ~ 2300 RPM				
	Gear steps / Range	A	36	50	70	105				
		B	130	180	250	380				
		C	620	900	1200	1800				
Threads and Feeds	Cross slide travel	250 mm (9.84")	260 mm (10.23")	250 mm (9.84")	260 mm (10.23")	250 mm (9.84")	260 mm (10.23")	250 mm (9.84")	260 mm (10.23")	
	Top slide travel	155 mm (6.1")				155 mm (6.1")				
	Whitworth threads: Kinds / Range	45 Kinds / 2 ~ 72 T.P.I.				45 Kinds / 2 ~ 72 T.P.I.				
	Metric threads: Kinds / Range	39 Kinds / 0.2 ~ 14 mm				39 Kinds / 0.2 ~ 14 mm				
	D.P. threads: Kinds / Range	21 Kinds / 8 ~ 44 D.P.				21 Kinds / 8 ~ 44 D.P.				
Tailstock	M.P. threads: Kinds / Range	18 Kinds / 0.3 ~ 3.5 M.P.				18 Kinds / 0.3 ~ 3.5 M.P.				
	Longitudinal feeds	0.04 ~ 1.0 mm (0.0015" ~ 0.04")				0.04 ~ 1.0 mm (0.0015" ~ 0.04")				
	Cross feeds	0.02 ~ 0.5 mm (0.00075" ~ 0.02")				0.02 ~ 0.5 mm (0.00075" ~ 0.02")				
	Quill diameter	Ø59 mm (2.322")				Ø59 mm (2.322")				
Motor	Quill travel	127 mm (5")				127 mm (5")				
	Taper of center	MT No. 4				MT No. 4				
	Main spindle	5 HP (3.75 kW)				5 HP (3.75 kW)				
Measurement	Forced lubrication for headstock	--				--				
	Coolant pump	1/8 HP (0.09375 kW)				1/8 HP (0.09375 kW)				
	Weight Approx	NET	1600 kgs	1750 kgs	1650 kgs	1800 kgs	1600 kgs	1750 kgs	1650 kgs	1800 kgs
GROSS		1800 kgs	2000 kgs	1850 kgs	2050 kgs	1800 kgs	2000 kgs	1850 kgs	2050 kgs	
Packing size	Length	2400 mm	2900 mm	2400 mm	2900 mm	2400 mm	2900 mm	2400 mm	2900 mm	
	Width x Height	Width 1120 (44.1") x Height 1900 mm (74.8")				Width 1120 (44.1") x Height 1900 mm (74.8")				

V : Variable

High Speed Precision Lathe

FC Series

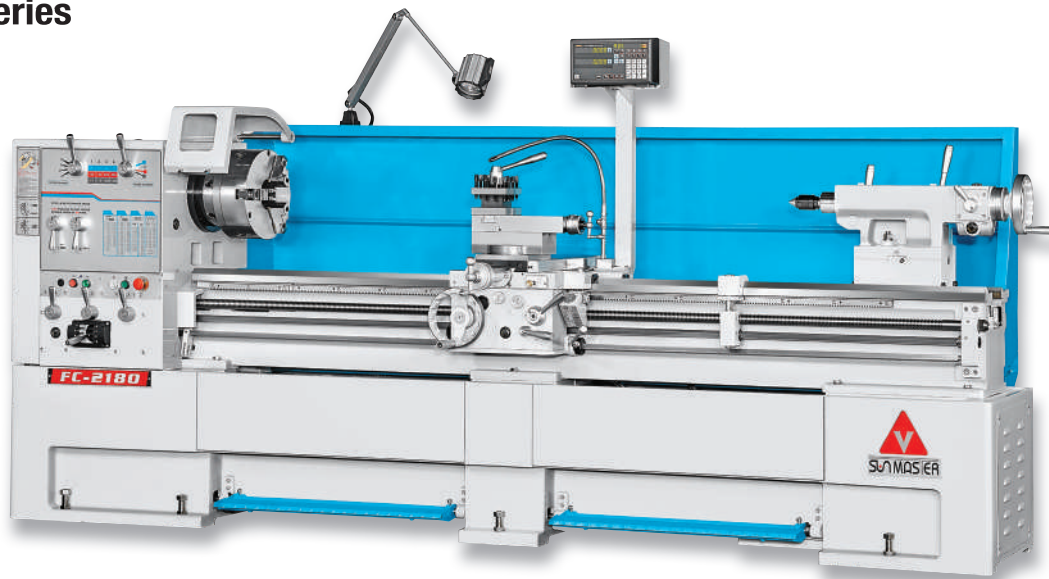

FC-2180



HEAVY DUTY SPINDLE

- Proven design on same models but with big spindle bore (80 mm) offering more efficient, durable operation.
- Spindle is made from forged alloy steel, hardened, ground & heat treated for dynamical balance.
- The spindle is supported at three points by high precision taper roller and ball bearings keeping rigidity and accuracy.



CARRIAGE & SLIDE

- Anti-Float design backlash eliminator fitted in cross slide nut.
- Safety clutch at feed shaft.
- One shot lubrication in carriage & top slide.
- Dual dials supply inch system screw.
- Metric dial supply metric system only.

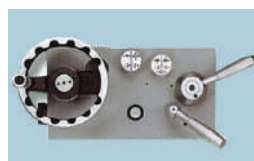

APRON

- R/H or L/H wheel available upon request.
- Integrated automatic control for longitudinal, cross, forward and reverse feed.



HEADSTOCK

- Housing is vibration resistance, deflection-free.
- Gears are hardened & MAAG or REISHAUER ground.

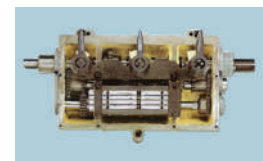

GEAR BOX

- Universal gear box allows inch or metric dial. Turing M.P., D.P. threads without gear change.

MACHINE SPECIFICATIONS

MODEL		FC-1640	FC-1660	FC-1840	FC-1860	FC-1880	FC-2140	FC-2160	FC-2180	
Capacity	Height of centers	205 mm (8.07")		231 mm (9.09")			271 mm (10.67")			
	Swing over bed	Ø410 mm (16.14")		Ø462 mm (18.18")			Ø542 mm (21.34")			
	Swing in gap	Ø598 mm (23.54")		Ø650 mm (25.59")			Ø730 mm (28.74")			
	Swing over cross slide	Ø255 mm (10.04")		Ø305 mm (12")			Ø387 mm (15.23")			
	Distance between centers	1000 mm (40")	1500 mm (60")	1000 mm (40")	1500 mm (60")	2120 mm (83.46")	1000 mm (40")	1500 mm (60")	2120 mm (83.46")	
Headstock and Main Spindle	Width of bed	320 mm (12.5")								
	Gap width in front of faceplate	195 mm (7.67")								
	Spindle nose, internal taper	D1-8 / A1-8 (opt.), Ø85 mm Taper 1/19,18								
	Spindle center sleeve	Ø85 mm Taper 1/19,18 x MT. x No.5								
	Spindle bore	Ø80 mm (3.149")								
Carriage	Spindle speed: Gear steps / Range			A	26	40	60	90	rpm	
				B	105	145	205	305	rpm	
				C	510	715	1000	1500	rpm	
Threads and Feeds	Cross slide travel	250 mm (9.84")		300 mm (11.81")						
	Top slide travel	150 mm (5.9")								
	Whitworth threads: Kinds / Range	45 kinds / 2~72 T.P.I..								
	Metric threads: Kinds / Range	39 kinds / 0.2~14 mm								
	D.P. threads: Kinds / Range	21 kinds / 8~44 D.P.								
Tailstock	M.P. threads: Kinds / Range	18 kinds / 0.3~3.5 M.P.								
	Longitudinal feeds	0.04~1.0 mm (0.0015~0.04")								
	Cross feeds	0.02~0.5 mm (0.00075~0.02")								
Motor	Quill diameter	Ø59 mm (2.322")		Ø68 mm (2.677")			Ø59 mm (2.322")		Ø68 mm (2.677")	
	Quill travel	127 mm (5")		153 mm (6")			127 mm (5")		153 mm (6")	
	Taper of center	MT. No.4								
Measurement	Main spindle	Std. 10 HP (7.5 kW) / Opt. 12.5 HP (9.375 kW)								
	Coolant pump	1/8 HP								
Measurement	Weight Approx	Net (kgs)	1750	1900	1800	1950	2450	1850	2000	2500
		Gross (kgs)	1950	2150	2000	2200	2850	2050	2250	2850
	Packing size	Length	2400 mm	2900 mm	2400 mm	2900 mm	3700 mm	2400 mm	2900 mm	3700mm
	Width x Height	Width 1155 mm (45.5") x Height 1900 mm (74.8")								

V : Variable

Precision Surface Grinder



KGS-616S



KGS-250AH/AHD



KGS-1020AH/AHD



KGS-63AH/AHD



KGS-84AH/AHD

MACHINE SPECIFICATIONS

SPECIFICATION		UNIT	KGS-616S	KGS-250AH/AHD	KGS-1020AH/AHD	KGS-63AH/AHD	KGS-84AH/AHD	
Capacity	Overall table working area	mm	410*160	460*200	500*250	600*300	800*400	
	Longitudinal table travel	mm	430	540	560	710	910	
	Cross feed table travel	mm	200	260	275	340	450	
	Distance spindle center to table	mm	440	475	490	600	600	
	Table load including magnetic chuck	kgs	100	100	250	420	700	
Table & Cross feed	T-Slot	mm*N	14*1	14*1	14*1	14*1	14*3	
	Longitudinal table speed	m/min		5~25	5~25	5~25	5~25	
	Cross feed on hand wheel	1 gra.	mm	0.02	0.02	0.02	0.02	0.02
		1 rev.	mm	4	4	4	4	5
	Auto cross feed per stroke	mm		0.25~12	0.25~12	0.25~20	0.25~20	
Power cross feed	50 Hz	mm/min		820	820	1000	1000	
	60 Hz	mm/min		980	980	1200	1200	
Grinding wheel	Wheel dimensions	mm	180*13*31.75	180*13*31.75	180*25*31.75	355*38*127	355*38*127	
	Spindle speed	50Hz	rpm	2850	2850	2850	1450	1450
		60 Hz	rpm	3480	3480	3480	1740	1740
Vertical movement	Vertical on hand wheel	1 gra.	mm	0.005	0.01	0.01	0.01/0.001	0.01/0.001
		1 rev.	mm	2	2	2	2/0.5	2/0.5
	Auto down feed elevation	mm		0.002~0.02(AHD)	0.002~0.02(AHD)	0.005~0.025(AHD)	0.005~0.025(AHD)	
	Power head increment	50 Hz	mm/min				133(AHD)	133 (AHD)
60 Hz		mm/min				160 (AHD)	160 (AHD)	
Motor	Spindle motor	KW*P	1.5*2	1.5*2	2.2*2	3.7*4	5.6*4	
	Power elevation motor	KW*P				0.08*6	0.08*6	
	Hydraulic motor	KW*P		0.75*4	1.5*4	1.5*6	2.2*6	
	Dust collection motor	W*P	375*2	375*2	375*2	375*2	375*2	
	Coolant motor	W*P	95*2	95*2	95*2	190*2	190*2	
	Cross feed motor	W*P		40*6	40*6	40*6	80*6	
Dimension & Weight	Machine height	mm	1645	1775	1775	1830	1875	
	Floor space	mm	1610*1120	1800*1400	2100*1800	2600*2500	3600*2600	
	Net weight	kgs	630	1300	1430	1750	2800	
	Gross weight	kgs	780	1500	1680	2200	3000	



KGS-510AH/AHD



KGS-615AHD



KGS-820 / 830 / 920 / 930AHD



KGS-620AHD

MACHINE SPECIFICATIONS

SPECIFICATION		UNIT	KGS-510AH/AHD	KGS-615AHD	KGS-620AHD	KGS-715AHD	KGS-820 / 825 / 830AHD			KGS-920 / 925 / 930AHD			
Capacity	Overall table working area	mm	1000*500	1500*600	2000*600	1500*700	2000*800	2500*800	3000*800	2000*900	2500*900	3000*900	
	Longitudinal table travel	mm	1140	1600	2230	1760	2250	2750	3250	2250	2750	3250	
	Cross feed table travel	mm	540	660	660	760		885			960		
	Distance spindle center to table	mm	575	600	600	600		880			880		
	Table load including magnetic chuck	kgs	1000	1300	1500	1400	2300	2800	3000	2300	2800	3000	
Table & Cross feed	T-Slot	mm*N	16*3	16*3	16*3	16*3		18*3			18*3		
	Longitudinal table speed	m/min	7~25	7~25	7~25	7~25		10~28			10~28		
	Cross feed on hand wheel	1 gra.	mm	0.02	0.02	0.02	0.02		0.01			0.01	
		1 rev.	mm	5	5	5	5		2			2	
	Auto cross feed per stroke	mm	0.25~20	0.25~20	0.25~20	0.25~20		2~30			2~30		
	Power cross feed	50 Hz	mm/min	1250	1250	1250	1250		1500			1500	
60 Hz		mm/min	1500	1500	1500	1500		1500			1500		
Grinding Wheel	Wheel dimensions	mm	355*38*127	355*50*127	355*50*127	355*50*127		508*50*127			508*50*127		
	Spindle speed	50Hz	rpm	1450	1450	1450	1450		950			950	
		60 Hz	rpm	1740	1740	1740	1740		1150			1150	
Vertical Movement	Vertical on hand wheel	1 gra.	mm	0.002	0.002	0.002	0.002		0.002			0.002	
		1 rev.	mm	0.5	0.5	0.5	0.5		0.5			0.5	
	Auto down feed increment	mm	0.005~0.04 (AHD)	0.005~0.04	0.005~0.04	0.005~0.04		0.005~0.04			0.005~0.04		
Power head elevation	50 Hz	mm/min	230	230	230	230		230			230		
	60 Hz	mm/min	280	280	280	280		280			280		
Motor	Spindle motor	KW*P	5.6*4	7.5*4	7.5*4	7.5*4		11.2*6			11.2*6		
	Power elevation motor	KW*P	0.19*4	0.375*4	0.375*4	0.375*4		0.375*4			0.375*4		
	Hydraulic motor	KW*P	2.2*6	3.7*6	3.7*6	3.7*6	7.5*6	11*6		7.5*6	11*6		
	Dust collection motor	W*P	375*2	375*2	375*2	375*2		375*2			375*2		
	Coolant motor	W*P	190*2	190*2	190*2	190*2		190*2			190*2		
	Cross feed motor	W*P	190*6	190*6	190*6	190*6		HYDRAULIC			HYDRAULIC		
Dimension & Weight	Machine height	mm	2400	2445	2470	2470		2850			2850		
	Floor space	kgs	4445*2100	5810*2645	6200*2700	5810*2800	6000*3360	7300*3360	8700*3360	6000*3400	7300*3400	8700*3400	
	Net weight	kgs	5000	6250	8500	7000	12000	13500	14000	12000	14000	16000	
	Gross weight	kgs	5800	7250	9700	8000	14000	15500	16000	14000	16000	18000	

Precision Surface Grinder-Wizard Series

WM1 : Programmable Downfeed Surface Grinder.

WM2 : Programmable Downfeed and Crossfeed Surface Grinder.

WMA1 : Programmable Downfeed Surface Grinder with Automatic Compensate Over-head Dresser.

WMA2 : Programmable Downfeed and Crossfeed Surface Grinder with Automatic Compensate Over-head Dresser.



**KGS-510WM1/WM2
-510WMA1/WMA2**



**KGS-620WM1/WM2
-620WMA1/WMA2**

MACHINE SPECIFICATIONS

SPECIFICATION		UNIT	KGS-250WM1/WM2	KGS-1020WM1/WM2	KGS-63WM1/WM2	KGS-84WM1/WM2	KGS-510WM1/WM2	KGS-615WM1/WM2
Capacity	Overall working area	mm	460x200	500x250	600x300	800x400	1000x500	1500x600
	Longitudinal and cross travel	mm	540x260	590x275	710x340	920x450	1140x540	1600x660
	Distance spindle center to table	mm	475	490	600	600	550	600
	Table load including magnetic chuck	kgs	100	250	420	700	1000	1300
Table & Cross Feed	Longitudinal table speed	WM1 m/min	1-28	1-28	1-28	1-28	7-28	7-28
		WM2 m/min	1-28	1-28	1-28	1-28	1-28	1-28
	Crossfeed on hand wheel (WM1)	1 gra. mm	0.02	0.02	0.02	0.02	0.02	0.02
		1 rev. mm	4	4	4	5	5	5
	Crossfeed on MPG (WM2)	1 gra. mm	0.001	0.001	0.001	0.001	0.001	0.001
		1 rev. mm	0.1	0.1	0.1	0.1	0.1	0.1
	Auto cross feed per stroke	WM1 mm	0.1-12	0.1-12	0.1-12	0.1-12	0.5-12	0.5-12
		WM2 mm	0-30	0-30	0-30	0-30	0-30	0-30
Rapid cross feed	WM1 (50/60Hz)	mm/min	820/ 980	820/980	1000/1200	1000/1200	1250/1500	1250/1500
	WM2	mm/min	1500	1500	1500	1500	1500	1500
Grinding Wheel	Wheel dimensions (ODxTxID)	mm	180x13x31.75	180x25x31.75	355x38x127	355x38x127	355x38x127	355x50x127
	Spindle speed (50Hz/ 60 Hz)	r.p.m	2850/ 3480	2850/3480	1450/1740	1450/1740	1450/1740	1450/1740
Vertical Movement	Vertical on hand wheel	1 gra. mm	0.001	0.001	0.001	0.001	0.001	0.001
		1 rev. mm	0.1	0.1	0.1	0.1	0.1	0.1
	Auto down feed increment	mm	0.001-0.099	0.001-0.099	0.001-0.099	0.001-0.099	0.001-0.099	0.001-0.099
Motor	Rapid elevating	mm/min	300	300	300	300	300	300
	Spindle motor	KWxP	1.5x2	2.2x2	3.7x4	5.6x4	5.6x4	7.5x4
	Elevating motor (AC Servo)	KW	0.4	0.4	0.4	0.4	0.75	0.75
	Cross feed motor	WM1 WxP	40x6	40x6	40x6	80x6	190x6	190x6
	WM2 KW	0.400	0.400	0.400	0.400	1.000	1.000	
Dimension & Weight	Machine height	mm	1775	1775	1830	1875	2400	2445
	Floor space	mm	1800x1400	2100x1800	2600x2500	3600x2600	4445x2100	5810x2445
	Net weight	kgs	1550	1680	2200	2800	5800	6250

SPECIFICATION		UNIT	KGS-620WM1/WM2	KGS-715WM1/WM2	KGS-820 / 825 / 830WM1/WM2			KGS-920 / 925 / 930WM1/WM2		
Capacity	Overall working area	mm	2000x600	1500x700	2000x800	2500x800	3000x800	2000x900	2500x900	3000x900
	Longitudinal and cross travel	mm	2230x660	1600x760	2250x885	2750x885	3250x885	2250x960	2750x960	3250x960
	Distance spindle center to table	mm	600	600	880	880	880	880	880	880
	Table load including magnetic chuck	kgs	1500	1400	2300	2800	3000	2300	2800	3000
Table & Cross Feed	Longitudinal table speed	WM1 m/min	7-28	7-28	7-28	7-28	7-28	7-28	7-28	7-28
		WM2 m/min	1-28	1-28	1-28	1-28	1-28	1-28	1-28	1-28
	Crossfeed on hand wheel (WM1)	1 gra. mm	0.02	0.02	0.01	0.01	0.01	0.01	0.01	0.01
		1 rev. mm	5	5	2	2	2	2	2	2
	Crossfeed on MPG (WM2)	1 gra. mm	0.001	0.001	0.001	0.001	0.001	0.001	0.001	0.001
		1 rev. mm	0.1	0.1	0.1	0.1	0.1	0.1	0.1	0.1
	Auto cross feed per stroke	WM1 mm	0.5-12	0.5-12	2-30	2-30	2-30	2-30	2-30	2-30
		WM2 mm	0-30	0-30	0-30	0-30	0-30	0-30	0-30	0-30
Rapid cross feed	WM1 (50/60Hz)	mm/min	1250/1500	1250/1500	1500	1500	1500	1500	1500	1500
	WM2	mm/min	1500	1500	1500	1500	1500	1500	1500	1500
Grinding Wheel	Wheel dimensions (ODxTxID)	mm	355x50x127	355x50x127	508x50x127			508x50x127		
	Spindle speed (50Hz/ 60 Hz)	r.p.m	1450/1740	1450/1740	950/1150			950/1150		
Vertical Movement	Vertical on hand wheel	1 gra. mm	0.001	0.001	0.001			0.001		
		1 rev. mm	0.1	0.1	0.1			0.1		
	Auto down feed increment	mm	0.001-0.099	0.001-0.099	0.001-0.099			0.001-0.099		
Motor	Rapid elevating	mm/min	300	300	300			300		
	Spindle motor	KWxP	7.5x4	7.5x4	11.2x6			11.2x6		
	Elevating motor (AC Servo)	KW	0.75	0.75	1.0			1.0		
	Cross feed motor	WM1 WxP	190x6	190x6	Hydraulic			Hydraulic		
	WM2 KW	1.000	1.000	1.000			1.000			
Dimension & Weight	Machine height	mm	2470	2470	2850			2850		
	Floor space	mm	6200x2700	5810x2800	6000x3360	7500x3360	8700x3360	6000x3700	7500x3700	8700x3700
	Net weight	kgs	8500	7000	12000	13500	14000	12000	14000	16000

■ Specifications subject to change without prior notice.



KGS -63WM1/WM2
KGS -63WMA1/WMA2



KGS -820WM1/WM2
KGS -820WMA1/WMA2



KGS -830WM1/WM2
KGS -830WMA1/WMA2

OPTIONAL ACCESSORIES

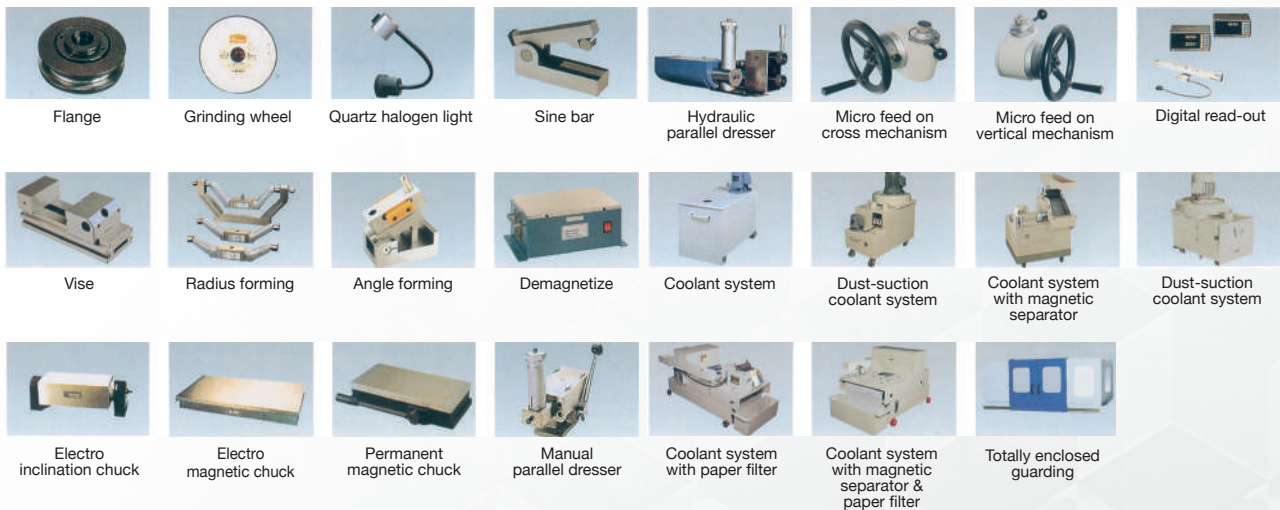

WIZARD SERIES FEATURES

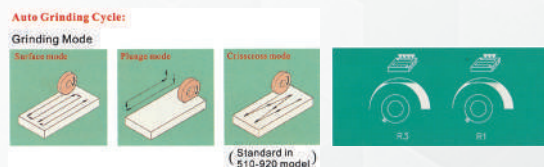

TOUCH SCREEN DESCRIPTION

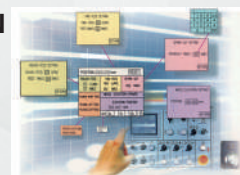

High Efficiency and Precision Radial Drills

Manual Clamping TPR-720A, TPR-820A, TPR-920A, TPR-1100



TPR-720A

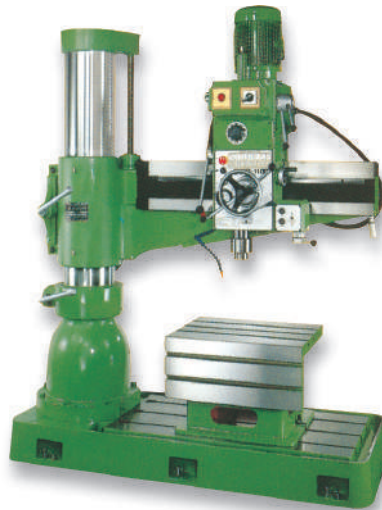

TPR-1100

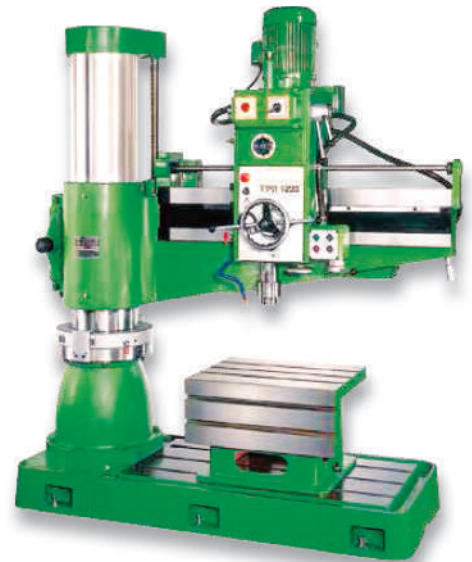

TPR-1230

MACHINE SPECIFICATIONS

MODEL	TPR-720A	TPR-820A	TPR-920A	TPR-1100	TPR-1230
Dia. of column		210		260	300
Distance from column surface to spindle center , Max	750	850	950	1120	1230
Distance from column surface to spindle center , Min	225	230	210	270	330
Travel of spindle head	540	640	755	850	880
Distance from base surface to spindle end , Max	1050	1210	1225	1280	1360
Distance from base surface to spindle end , Min	260	375	385	480	467
Elevating height of arm	580	625	625	560	620
Effective area of box table		600x445x380		635x520x415	
Dimension of base	1250x640x160	1250x640x160	1260x640x160	1720x715x185	
Taper hole spindle		MT#4		MT#4	
Stroke of spindle		210		240	270
R.P.M of spindle (rpm x steps)	50HZ	73-1247 x 6		37-1253 x 12	
	60HZ	88-1500 x 6		44-1500 x 12	
Feed of spindle (rev. x steps)		0.05, 0.09, 0.15 x 3		0.05, 0.09, 0.15x3	
Main motor (HP)		2HP		3 (two speed motor)	
Elevating motor (HP)		1HP		1HP	
Hydraulic clamping motor (HP)					1HP
Coolant equipment (HP)		1/8 HP		1/8 HP	
Machine height from floor (Max.)	2160	2320	2340	2570	2670
Base + column height	1820	2010	2020	1990	2070
Net weight (approx)kgs	1175(kg)	1200(kg)	1280(kg)	1800(kg)	2100(kg)
Shipping weight (approx) kgs	1320(kg)	1350(kg)	1400(kg)	1950(kg)	2300(kg)
Shipping dimensions (LxWxH)	1630x810x2160	1680x810x2210	1800x810x2210	1880x860x2210	2030x990x2040
Capacity	Drilling	Steel	32Ø		42Ø
		Cast iron	50Ø		55Ø
	Tapping	Steel	25Ø		25Ø
		Cast iron	32Ø		38Ø

Hydraulic Clamping

TPR-1230H, TC-1250H, TC-1600H, TPR-1600H, TPR-2000H, TPR-C2500

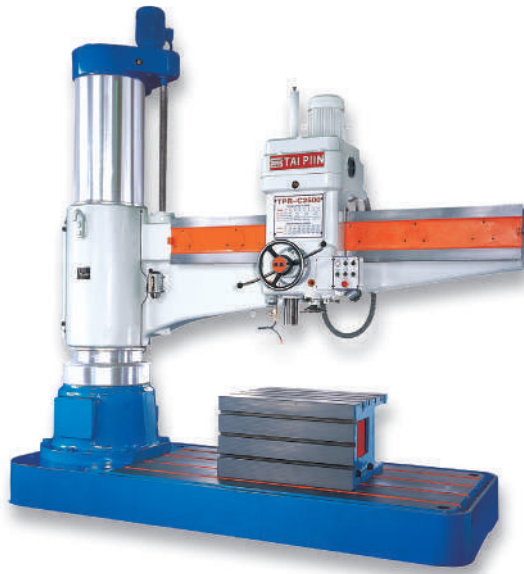

TPR-C2500



TPR-1600H

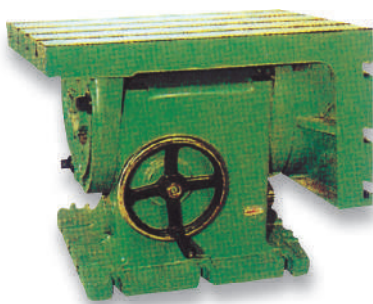

Standard accessory:
 Adjustment tools (box included)..... 1 set
 Cooling device (pump included)..... 1 set
 Lighting device (fluorescent lamp included)..... 1 set
 Box-type work table..... 1 set

Special optionals/ Tilt tables
 Uni-tilt table tilts full 90 degrees. Calibrated indicator shows degree of tilt has accurately planed top

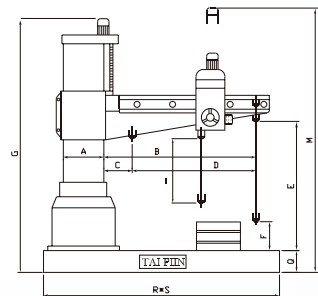

MACHINE SPECIFICATIONS

MODEL	TPR-1230H	TC-1250H	TC-1600H	TPR-1600H	TPR-2000H	TPR-C2500
Dia. of column	300	300	320	432	432	550
Distance from column surface to spindle center , Max	1230	1275	1650	1550	2060	2500
Distance from column surface to spindle center , Min	330	305	330	440	440	500
Travel of spindle head	880	970	1320	1110	1620	2000
Distance from base surface to spindle end , Max	1360	1330	1405	1640	1950	2000
Distance from base surface to spindle end , Min	467	438	465	380	395	550
Elevating height of arm	620	625	670	875	1185	1000
Effective area of box table	635x520x415	635x520x420	630x500x500	700x500x400	1000x800x500	1000x800x560
Dimension of base	1720x715x185	1830x785x185	2550x970x200	2470x1030x200	1185	3520x1400x320
Taper hole spindle	MT#4		MT5		MT#5	MT#6
Stroke of spindle	270		270		370	450
R.P.M of spindle (rpm x steps)	50HZ	37-1253 x 12		44-1206 x 12	29-1575 x 12	16-1250 x 16
	60HZ	44-1500 x 12		56-1450 x 12	35-1890 x 12	16-1250 x 16
Feed of spindle (rev. x steps)		0.05, 0.09, 0.15x3		0.06, 0.10, 0.20x3	0.07~0.96x6	0.04~3.20 x16
Main motor (HP)		3 (two speed motor)		5 (two speed motor)	7 - 1/2HP	10HP
Elevating motor (HP)		1HP		1HP	2HP	3HP
Hydraulic clamping motor (HP)		1HP		1HP	1HP	1HP
Coolant equipment (HP)		1/8HP		1/8HP	1/8HP	1/4HP
Machine height from floor (Max.)	2670	2795	2790	3130	3520	3990
Base + column height	2070	2070	2190	2660	3050	3850
Net weight (approx)kgs	2100	2300	3300	4250	5600	11000
Shipping weight (approx)kgs	2300	2500	3650	4700	6100	12500
Shipping dimensions (LxWxH)	2030x990x2240	2220x1000x2240	2700x1130x2430	2820x1450x2930	3200x1450x3300	4160x1880x3850
Capacity	Drilling	Steel	42Ø	50Ø	65Ø	80Ø
		Cast iron	55Ø	60Ø	70Ø	100Ø
	Tapping	Steel	25Ø	40Ø	50Ø	65Ø
		Cast iron	38Ø	50Ø	60Ø	75Ø

CNC Automatic Carbide Sawing Machine High-Speed for non-ferrous metals

- Automatic for Metals
- Automatic for non-ferrous metals



KTC-100NF



KTC-150NF



Chip Suction Device

MACHINE SPECIFICATIONS

MODEL		KTC-100NF		KTC-150NFC		KTC-200NFC
Cut-off Capacity	Round bar ●	8 ~ 100 mm	0.314 ~ 3.937 in	20 ~ 150 mm	0.787 ~ 5.905 in	90 ~ 204 mm
	Square bar ■	8 ~ 80 mm	0.314 ~ 3.149 in	20 ~ 125 mm	0.787 ~ 4.921 in	80 ~ 175 mm
	Hexagon bar ●	8 ~ 80 mm	0.314 ~ 3.149 in	20 ~ 130 mm	0.787 ~ 5.118 in	80 ~ 175 mm
Saw Head & Spindle	TCT Carbide tipped sawblade type	Ø 355 x 2.0 mm		Ø 480 x 2.7 mm		Ø 650 x 3.5 mm
	Sawblade rotation speed	1600 ~ 4000 rpm / Variable speed via frequency inverter		1000 ~ 3200 rpm / Variable speed via frequency inverter		1300 ~ 2535 rpm / Variable speed via frequency inverter
	Driving motor of spindle	11 kw (15Hp) / 2p		15 kw (20Hp) / 2p		30 kw (40Hp) / 2p
	Saw head feeding	AC Servo motor (2kw) / Pivot-arm type		AC Servo motor (5kw) / Sloping type / Linear guideway		AC Servo motor (2kw) / Linear Guided
	Main vise	Horizontal / Vertical / Hydraulic		Horizontal / Vertical / Hydraulic		Horizontal / Vertical / Hydraulic
Gripper Feed Carriage (GFC) Feeding System	GFC feed stroke	(Once)	6 ~ 800 mm 0.236 ~ 31.496 in	6 ~ 800 mm 0.236 ~ 31.496 in		6 ~ 450 mm
		(Multiple)	9999 mm 393.661 in			9999 mm
Auto-Loading Magazine Attachment	Capacity	2000 ~ 6000 mm	6.65 ~ 20 ft	2000 ~ 6000 mm	6.65 ~ 20 ft	2000 ~ 6000 mm
	Pre-loading width	980 mm	38.582 in	1220 mm	48.031 in	2080 mm
	Pre-loading weight (at static load)	3600 kgs	7920 lbs	9500 kgs	20900 kgs	20000 kgs
Hydraulic Device	Hydraulic oil tank	90 liters	23.78 gallons	100 liters	26.46 gallons	100 liters
Machine Dimension & Weight	Dimension (L x W x H)	6565 x 1772 x 1735 mm	21.54 x 5.81 x 5.69 ft	7280 x 2990 x 1908 mm	23.88 x 9.81 x 6.26 ft	7280 x 3000 x 1910 mm
	Weight (machine / loader)	2200 / 700 kgs	4840 / 1540 lbs	4000 / 1250 kgs	8800 / 2750 kgs	4000 / 1500 kgs

High-Speed Circular Sawing Machine for Alloy Steel metals

- Amazing Precise and High-speed cutting speed
- Mass production requirement
- Environment Dry & Clean at cutting



KTC-130SP

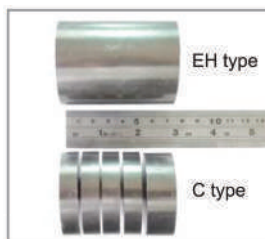

The shortest remnant achievement 20mm (With Move Vise)



WATCH VDO



MACHINE SPECIFICATIONS

MODEL	KTC-65E		KTC-70EH (C)		KTC-100EH (C)		KTC-130SP		KTC-150SP		KTC-200SP (C)		KTC-230LC		
Cut-off Capacity	Round bar ●	8-50 mm	8-70 mm	8-70 mm (0.314-2.755in)	8-85 mm (0.314-3.346in)	12-531/1022/1103 mm (0.472-2.080/4.000/4.330 in)	20-100/130 mm	0.787-4.000 / 5.118 in (1.574-6.000 in)	40-153 mm (1.574-6.000 in)	20-88 mm (0.787-3.464 in)	40-200 mm (1.574-7.874 in)	90-230 mm	3.543-9.055 in		
	Square bar ■	8-40 mm	8-55 mm	8-57 mm (0.314-2.244in)	8-65 mm (0.314-2.559in)	12-401/852/853 mm (0.472-1.575/3.346/3.346 in)	20-75/105 mm	0.787-2.953 / 4.133 in (1.574-4.330 in)	40-110 mm (1.574-4.330 in)	20-65 mm (0.787-2.559 in)	40-165 mm (1.574-6.496 in)	90-195 mm	3.149-7.677 in		
	Hexagon bar ●	8-45 mm	8-60 mm	8-60 mm (0.314-2.362in)	8-70 mm (0.314-2.755in)	12-451/852/953 mm (0.472-1.772/3.346/3.740 in)	20-87/120 mm	0.787-3.425 / 4.724 in (1.574-5.118 in)	40-130 mm (1.574-5.118 in)	20-76 mm (0.787-2.992 in)	40-180 mm (1.574-7.086 in)	90-200 mm	3.149-7.874 in		
Saw Head & Spindle	TCT Carbide tipped sawblade type	Ø 250x2.0 / Ø 285x2.0 mm		Ø 285x2.0 mm	Ø 315x2.25 mm	Ø 2851 x 2.0 / Ø 3602 x 2.6 / Ø 3703 x 2.6 mm	Ø 360 x 2.6 / Ø 425 x 2.7 mm	Ø 460x2.7 mm	Ø 360 x 2.6 mm	Ø 650 x 3.5 mm	Ø 750/4.0x3.4xØ80 mm				
	HSS High-speed steel sawblade type	Ø250-Ø275 / 2.0t-2.5t mm		Ø325 x 2.0t-3.0t mm		Ø360 / 2.0t-4.0t mm (Max)	Ø 425 / 3.0t-5.0t mm	Ø 460 / 3.0t-5.0t mm	Ø 650 / 3.0t-5.0t mm	Ø 750 / 3.0t-5.0t mm					
	Sawblade rotation speed	18-200 rpm / Variable speed via frequency inverter		18-200 rpm / Variable speed via frequency inverter		20-180 rpm / Variable speed via frequency inverter	20-160 rpm / Variable speed via frequency inverter	20-160 rpm / Variable speed via frequency inverter	20-150 rpm / Variable speed via frequency inverter	20-150 rpm / Variable speed via frequency inverter	30-90 rpm / Variable speed via frequency inverter				
	Driving motor of spindle	9.7 kw (13Hp) / 4p		11.25 kw (15Hp) / 4p		15 kw (20Hp) / 4p	15 kw (20Hp) / 4p	18.75 kw (25Hp) / 4p	22.5 kw (30Hp) / 4p	37.5 kw (50Hp) / 4p					
	Cutting backlash compensation device	Powder brake		Powder brake		Powder brake	Powder brake	Powder brake	Powder brake	Powder brake	Powder brake				
	Sawblade antivibration parallel guide	Tungsten carbide plate		Tungsten carbide plate		Tungsten carbide plate	Tungsten carbide plate	Tungsten carbide plate	Tungsten carbide plate	Tungsten carbide plate	Tungsten carbide plate				
	Chip scraper	Steel brush disc		Steel brush disc		Steel brush disc (Power type)	Steel brush disc (Power type)	Steel brush disc (Power type)	Steel brush disc (Power type)	Steel brush disc (Power type)	Steel brush disc (Power type)				
	Sawblade feeding	AC Servo motor (2kw) / Pivot-arm type		AC Servo motor (2kw) / C5 grade Ball-Screw/Pivot type		AC Servo motor (2kw) / C5 grade Ball-Screw/Pivot type	AC Servo motor (5kw) / 30' Sloping type / Linear guideway	AC Servo motor (5kw) / 30' Sloping type / Linear guideway	AC Servo motor (7kw) / Sloping type / Linear guideway	AC Servo motor (7kw) / Linear guideway	AC Servo motor (7kw) / Linear guideway				
Main vise	Horizontal / Vertical / Hydraulic		Horizontal / Vertical / Hydraulic		Horizontal / Vertical / Hydraulic	Horizontal / Vertical / Hydraulic	Horizontal / Vertical / Hydraulic	Horizontal / Vertical / Hydraulic	Horizontal / Vertical / Hydraulic	Horizontal / Vertical / Hydraulic					
Gripper Feed Carriage (GFC) Feeding System	GFC feed stroke	(One)	6-800 mm	0.236-31.496in	6-800 mm	0.236-31.496in	6-800 mm	0.236-31.496 in	6-800 mm	0.236-31.496 in	6-800 mm	0.236-31.496 in	6-450 mm	0.236-17.716 in	
		(Multiple)	9999 mm	393.661 in	9999 mm	393.661 in	9999 mm	393.661 in	9999 mm	393.661 in	9999 mm	393.661 in	9999 mm	393.661 in	
Auto-Loading Magazine Attachment	Capacity	2000-6000mm	6.65-20 ft	2000-6000mm	6.65-20 ft	2000-6000 mm	6.65-20 ft	2000-6000 mm	6.65-20 ft	2000-6000 mm	6.65-20 ft	2000-6000 mm	6.65-20 ft	2000-6000 mm	6.65-20 ft
	Pre-loading width	980 mm	38.582 in	980 mm	38.582 in	890 mm	35.039 in	1220 mm	48.031 in	1220 mm	48.031 in	1220 mm	48.031 in	3545 mm	139.500 in
	Pre-loading weight (at static load)	3600 kgs	7920 lbs	3600 kgs	7920 lbs	4500 kgs	9900 lbs	9500 kgs	20900 lbs	9500 kgs	20900 lbs	16000 kgs	35200 lbs	9500 kgs	20900 lbs
Hydraulic Device	Hydraulic oil tank	90 liters	23.78 gallons	90 liters	23.78 gallons	90 liters	23.78 gallons	100 liters	26.46 gallons	100 liters	26.46 gallons	100 liters	26.46 gallons	100 liters	26.46 gallons
Machine Dimension & Weight	Dimension (L x W x H)	6565 x 1772 x 1735 mm	21.54 x 5.81 x 5.69 ft	6920 x 2492 x 1745 mm	22.70 x 8.18 x 5.73 ft	6915 x 2492 x 1816 mm	22.69 x 8.18 x 5.96 ft	7280 x 2990 x 1908 mm	23.88 x 9.81 x 6.26 ft	7280 x 2990 x 1908 mm	23.88 x 9.81 x 6.26 ft	7280 x 2990 x 2086 mm	23.88 x 9.81 x 6.82 ft	8181 x 4202 x 2086 mm	26.84 x 13.78 x 6.84 ft
	Weight (machine / loader)	2200/700 kgs	4840/1540 lbs	2800/700 kgs	6160/1540 lbs	3000/950 kgs	6620/2090 lbs	4300/1250 kgs	9460/2750 lbs	4500/1250 kgs	9900/2750 lbs	4800/1850 kgs	10560/4070 lbs	6665/6050 kgs	14660/13310 lbs

Drilling Machine Tapping Machine

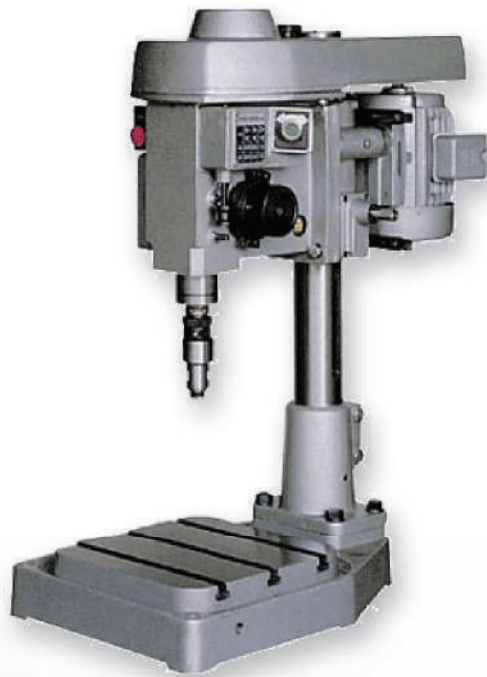

GT-223

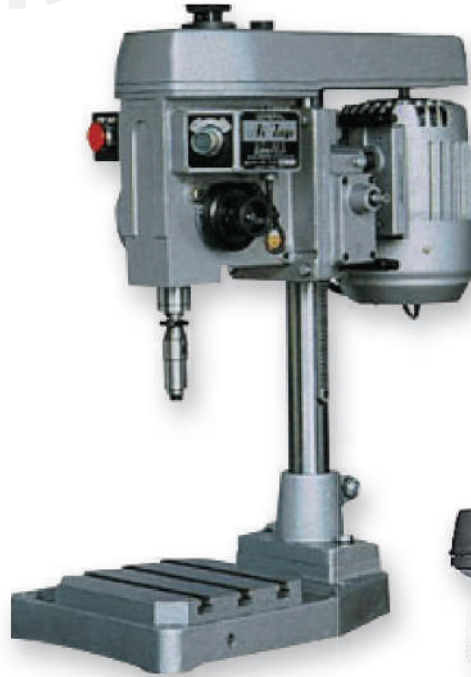

GT-203



GT-231

MACHINE SPECIFICATIONS

		GT1-203 (97Kg) Vertical type	GT2-223 (200kg) Vertical type	GT3-231 (250kg) Vertical type
Maximum main shaft stroke (mm)		45	65	65
Rotation diameter (mm)		330	430	460
Thread diameter (mm)		2Ø ~ 8ØUnder (10Ø)	5Ø ~ 16 Ø	10Ø ~ 32Ø
Head up and down moving distance (mm)		260	300	450
Distance between main shaft and workstation (mm)		350	470	600
Work station dimension (mm)		225 x 230	340 x 340	340 x 380
Base area (mm)		415 x 300	580 x 425	600 x 480
Motor		3Phases 4P 400W (1/2HP)	3Phases 6P 750W (1HP)	3Phases 6P 1.5KW (2HP)
Main shaft rotation number	50HZ	1340, 760, 420	515, 285, 155	200,100,50
	60HZ	1600, 900, 500	620, 340, 190	240,120,60
Automated threading distance applicable to this machine	Thread number per inch	64, 56, 48, 44, 40, 32, 28, 24, 20, 18, 16	28, 24, 20, 19, 18, 16, 14, 12, 11, 10	19,16,14,12,11,10,9,8
	mm	0.2, 0.25, 0.3, 0.35, 0.4, 0.45, 0.5, 0.6, 0.7, 0.75, 0.8, 0.9, 1.0, 1.25, (11.5)	0.7, 0.8, 0.9, 1.0, 1.25, 1.5, 1.75, 1.8, 2.0, 2.5	1.5,1.75,2.0,2.5,3.0,3.5
Multiple shaft maximum power (m/m standard thread distance)		3Øx10Shaft, 4Øx5Shaft, 5Øx2Shaft	6Øx9Shaft, 8 Øx4Shaft, 12 Øx2Shaft	10Øx10Shaft, 16Øx4Shaft, 20Øx2Shaft

Drilling Machine Tapping Machine



GHD-14

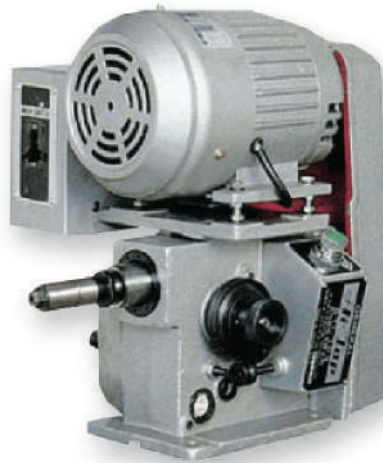

GT1-204



GT-223



GT2-224

MACHINE SPECIFICATIONS

ITEMS	GHD-14S Manual drilling machine		GHD-14T Electronic Tapping Machine		GHD-14A Auto-feed drilling machine	
Max. capacity	Ø16 (S45C)		Drilling: Ø16; tapping: M12		Drilling: Ø16	
Spindle stroke	100mm		100mm		93mm	
Horsepower	1HP4P		1HP4P		1HP4P	
Speed variation	4		9		4	
Rotation speed	50HZ	480-2300	50HZ	250-960	50HZ	466-1675
	60HZ	550-2700	60HZ	300-1150	60HZ	560-2010
Spindle type	Spindle tape	MT2#	Spindle tape	MT2#	Spindle tape	MT2#
	Spindle nose	JT6 1/2#	Spindle nose	JT6 1/2#	Spindle nose	JT6 1/2#
Weight	92kg		104kg		102kg	

ITEMS		GT1-204 (50kg) Horizontal type	GT2-224 (103kg) Horizontal type	GT3-232 (125kg) Horizontal type
Maximum main shaft stroke (mm)		45	65	65
Rotation diameter (mm)		330	430	460
Thread diameter (mm)		2Ø ~ 8ØUnder (10Ø)	5Ø ~ 16 Ø	10Ø ~ 32Ø
Head up and down moving distance(mm)		260	300	450
Distance between main shaft and workstation (mm)		350	470	600
Work station dimension (mm)		225 x 230	340 x 340	340 x 380
Base area (mm)		415 x 300	580 x 425	600 x 480
Motor		3Phases 4P 400W (1/2HP)	3Phases 6P 750W (1HP)	3 Phrase 6P 1.5KW (2HP)
Main shaft rotation number	50HZ	1340, 760, 420	515, 285, 155	200, 100, 50
	60HZ	1600, 900, 500	620, 340, 190	240, 120, 60
Automated threading distance applicable to this machine	Thread number per inch	64, 56, 48, 44, 40, 32, 28, 24, 20, 18, 16	620, 340, 190	19, 16, 14, 12, 11, 10, 9, 8
	mm	0.2, 0.25, 0.3, 0.35, 0.4, 0.45, 0.5, 0.6, 0.7, 0.75, 0.8, 0.9, 1.0, 1.25, (11.5)	0.7, 0.8, 0.9, 1.0, 1.25, 1.5, 1.75, 1.8, 2.0, 2.5	1.5, 1.75, 2.0, 2.5, 3.0, 3.5
Multiple shaft maximum power (m/m standard thread distance)		3Øx10Shaft, 4Øx5Shaft, 5Øx2Shaft	6Øx9Shaft, 8 Øx4Shaft, 12 Øx2Shaft	10Øx10Shaft, 16Øx4Shaft, 20Øx2Shaft

Vertical Turret Milling Machine



PBM-5KA

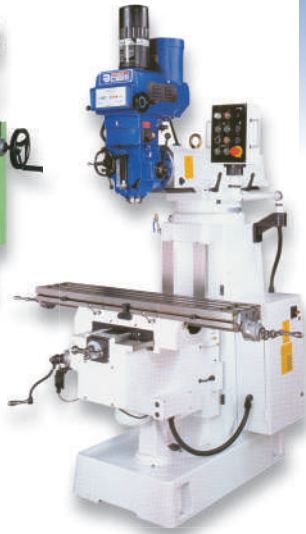

PBM-5VK



PBM-5K

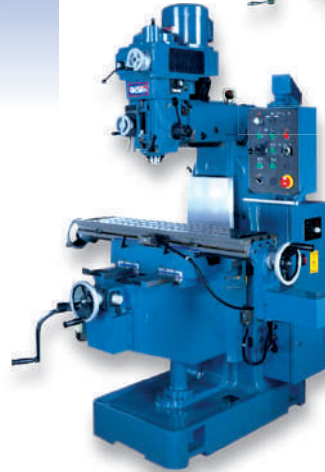

PBM-VS360A

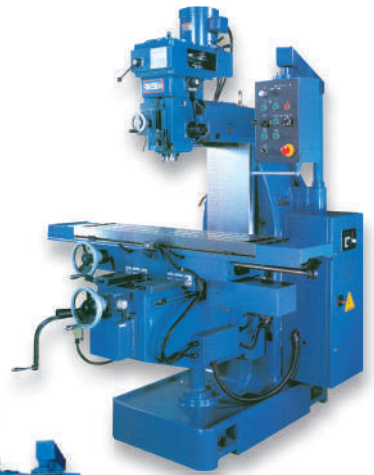

PBM-S500A

MACHINE SPECIFICATIONS

ITEMS		PBM-5KA	PBM-5VKA	PBM-5K	PBM-5VK	PBM-4EVS
Table	Table size	1370 x 254		1270 x 254 (1370 x 254 OPT.)		1270 x 254 (1370 x 254 OPT.)
	T Slot (W x NO. x Pitch)	16 x 3 x 63		16 x 3 x 63		16 x 3 x 63
Travel	X · Y · Z - Manual	900 x 400 x 450		775 x 400 x 450		775 x 400 x 406
	X · Y · Z - Auto	820 x 400 x 450		700 x 400 x 450		700 x 400 x 406
Feed	Long / Cross / Min	800 OPT.		360		
	Verti. rapid traverse / Min	360		430		
Spindle nose	Spindle nose	N.S.T. 40		N.S.T. 40		R8 / N.S.T. 30
	Steps	16	Variable	10	Variable	Inverter Vari
Vertical Spindle	Spindle speed RPM	60-3000	75-3165	60-3000 (50Hz) 70-3600 (60Hz)	66-3165 (50Hz) 80-3800 (60Hz)	60-3600 (50/60Hz)
	Swivelling angle	45° (R&L)		45° (R&L)		45° (R&L)
	Quill travel	140		127		127
	Quill feeds / REV	0.035 / 0.07 / 0.14		0.04 / 0.08 / 0.15		0.04 / 0.08 / 0.15
	Spindle nose to table	150-600		55-505		40-446
	Spindle center to column	130-550		130-550		200-680
	Cross travel of ram	420		420		480
	Horizontal rotation of ram	360°		360°		360°
Motor	Vertical spindle	5HP-2P/4P	5HP-4P	5HP-4P	5HP-4P	3HP-4P INV.
	Z Axis motor		1/2HP-4P-1/10		1/2HP-4P-1/10	
	Coolant pump		1/8HP-2P		1/8HP-2P	1/8HP-2P OPT
Size	Machine (L x W x H)	1900 x 1500 x 2400		1480 x 1435 x 2330		1500 x 1500 x 2200
	Net weight (kgs)	1600	1650	1500	1550	1280

* Specifications May be Changed or improved without Notice

A = Ball screw

V = Variable

E = Inverter

ITEMS		PBM-S360A	PBM-VS360A	PBM-EVS360A
Table	Table size	1200 x 280 (1270 x 370 OPT.)		
	T Slot (W x No. x Pitch)	16 x 3 x 65 (18 x 3 x 80 OPT.)		
Travel	X x Y x Z - Manual	700 x 360 x 360 (900 x 360 x 360 OPT.)		
	X, Y	Manual		
Feed	Z axis rapid / Min	960 (50 Hz) 1150 (60 Hz)		
	X, Y / Min	30-3000 Vari. (OPT.)	(50 / 60 Hz)	
Spindle nose	Spindle nose	N.S.T. 40		
	Steps	16	Variable	Inverter Vari.
Vertical Spindle	Spindle speed RPM	62-3000 (50 Hz) 75-3600 (60 Hz)	75-3165 (50 Hz) 90-3800 (60 Hz)	60-3600 (50 / 60 Hz)
	Swivelling angle		45° (R&L)	
	Quill travel		140	
	Quill feeds / REV		0.035 / 0.07 / 0.14	
	Spindle nose to table		0-500	
	Spindle center to column		185-635	
	Cross travel of ram		450	
	Horizontal rotation of ram		360°	
Motor	Vertical spindle	5HP - 2P/4P	5HP - 4P	5HP - 4P INV.
	Feed X, Y Axes		(AC Servo 750W OPT.)	
	Feed Z Axis		1HP - 12P (AC Servo 850W OPT.)	
	Coolant pump		1/8HP - 2P	
Size	Machine (L x W x H)	1900	1710 x 1560 x 2285	2000
	Net weight (kgs)	1900	1950	2000

* Specifications May be Changed or improved without Notice

A = Ball screw

V = Variable

E = Inverter

ITEMS		PBM EVS500A	PBM-S500A	PBM-S300A	PBM-VS300A
Table	Table size	1270x370 (1470x370 OPT.)		1270x300 (1470x300 OPT.)	
	T Slot (W x No. x Pitch)	18 x 3 x 80		16 x 3 x 80	
Travel	X · Y · Z - Manual	930 x 520 x 360		930 x 400 x 450	
	X · Y · Z - Auto	920 x 500 x 360		920 x 380 x 450	
Feed	Long / Min	30-3000		22-384 (6 Steps)	
	Long rapid traverse / Min	1250		430	
Spindle nose	Vertical rapid traverse / Min	1150			
	Spindle nose		N.S.T. 40		
Vertical Spindle	Steps	Inverter Vari.	16	Variable	
	Spindle speed RPM	60-3600	75-3600	62-3000	75-3165
	Swivelling angle		45° (R&L)		
	Quill travel		140		
	Quill feeds / REV		0.035 / 0.07 / 0.14		
	Spindle nose to table		0-500		20-470
	Spindle center to column		185-685		130-550
	Cross travel of ram		500		420
Motor	Horizontal rotation of ram		360°		
	Vertical spindle	5HP-4P		5HP-2P/4P	5HP-4P
	Feed long				3/4HP-4HP
	X, Y Axes motor	750W AC Servo			1/2HP -4P-1/5
Size	Z Axis motor	1 HP-12P (850W AC Servo OPT.)		1/2HP -4P-1/10	
	Coolant pump		1/8HP-2P		
Size	Machine (L x W x H)	1870 x 1700 x 2285		1740 x 1540 x 2300	
	Net weight (kgs)	2250		1650	1700

* Specifications May be Changed or improved without Notice

Vertical & Horizontal Milling Machine

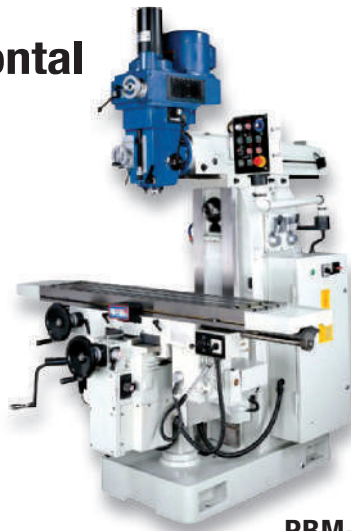

PBM-GS300A



PBM-GEVS500A

MACHINE SPECIFICATIONS

ITEMS	PBM-GS300A	PBM-GEVS500A	
Table	Table size	1270 x 300 (1470 x 300 OPT.)	1270 x 370 (1470 x 370 OPT.)
	T Slot (W x NO. x PITCH)	16 x 3 x 80	18 x 3 x 80
Travel	X · Y · Z - Manual	930 x 400 x 450	930 x 520 x 440
	X · Y · Z - Auto	920 x 380 x 450	920 x 500 x 420
Feed	Long / Min	18~320 (6 Steps) (50 Hz) 22~384 (6 Steps) (60 Hz)	30~3000 Vari. (50 / 60 Hz)
	Long rapid traverse / Min	1040 (50 Hz) 1250 (60 Hz)	
	Cross / Min	50~2200 Vari. (50 / 60 Hz)	30~3000 Vari. (50 / 60 Hz)
	Vertical / Min	360 (50 Hz) 430 (60 Hz)	960 (30~1150 Vari. OPT) (50 Hz) 1150 (30~1150 Vari. OPT) (60 Hz)
Spindle	Spindle nose	N.S.T. 40	N.S.T. 40
	Steps	16	Inverter Vari.
	Spindle speed RPM	62~3000 (50 Hz) 75~3600 (60 Hz)	60~3600 (50 / 60 Hz)
	Swivelling angle		45° (R&L)
	Quill travel		140
	Quill feeds / REV		0.035 / 0.07 / 0.14
	Spindle nose to table	95~545	85~505

ITEMS	PBM-GS300A	PBM-GEVS500A	
Spindle	Spindle center to column	190~690	185 ~785
	Cross travel of ram	500	600
Horizontal Spindle	Spindle nose		N.S.T. 40
	Spindle speed RPM		60~1440 (50 Hz) 65~1500 (60 Hz)
	Steps		9
	Spindle to bottom of ram		175
Motor	Spindle center to table	0~450	-25~395
	Vertical spindle	5HP~2/4P	5HP~4P INV.
	Horizontal spindle		5HP~4P
	Table feed X Axis	3/4HP~4P	
	Table feed Y Axis	1/2HP~4P~1/5	AC Servo 750W
	Table feed Z Axis	1/2HP~4P~1/10	1HP~12P (AC servo 850W OPT.)
	Coolant pump		1/8 HP~2P
Size	Machine (L x W x H)	1740 x 1614 x 2007	2070 x 2050 x 2600
	Net weight (KGS)	2350	2700

* Specifications May be Changed or improved without Notice

Vertical Milling Machine



PBM-5VSB



PBM-ST1200

MACHINE SPECIFICATIONS

ITEMS	PBM-5VSB	PBM-ST1200	
Table	Table size	1270 x 254 (1370 x 254 OPT.)	1470 x 350
	T Slot (W x NO. x PITCH)	16 x 3 x 63	18 x 3 x 100
Travel	X · Y · Z - Manual	775 x 430 x 550	
	X · Y · Z - Auto	700 x 410 x 540	1200 x 520 x 600
Feed	Long / Min	Manual	30~3000 Vari. (50 / 60 Hz)
	Cross / Min	Manual	30~3000 Vari. (50 / 60 Hz)
	Vertical / Min	565 (50 Hz) 680 (60 Hz)	30~3000 Vari. (50 / 60 Hz)
Spindle	Spindle nose	N.S.T. 40	N.S.T. 50
	Steps	Variable	Inverter variable
	Spindle speed RPM	66~3165 (50 Hz) 80~3800 (60 Hz)	60~1500 Vari. (50 / 60 Hz)
	Swivelling angle	45° (R&L)	fixed

ITEMS	PBM-5VSB	PBM-ST1200	
Spindle	Quill travel	127	
	Quill feeds / REV	0.04 / 0.08 / 0.15	
	Spindle nose to table	155~695	54~654
	Spindle center to column	450	185~785
Motor	Cross travel of ram		520
	Vertical Spindle	5HP - 4P	15HP~6P INV.
	Horizontal spindle		15HP
	Table feed X Axis		
	Table feed Y Axis		AC Servo 850W
Size	Table feed Z Axis	1/2HP~4P~1/5	
	Coolant pump		1/8 HP~2P
Size	Machine (L x W x H)	1870 x 1485 x 2330	2334 x 2005 x 2490
	Net weight (KGS)	2350	4100

* Specifications may be changed or improved without notice

Hot-Forging-Presses-FP

SPECIFICATION	
Advantages	Design
High Production Efficiency Longer Die Life	High Stroke Speed Ram and Bed Ejection Design
High Precision Forging Parts Stable Product Quality	Extended Eight-Faced Guide Ways Unique Connecting Rod Design
High Safety Standard Ensure the Safety for Operator and Machine	PLC Multi Circuit Loop System, Micro Computer Load Meter
Fulfill the Environmental Protection Standards	Flywheel Transmission Has Low Noise Decibel
Easy to Maintenance Easy to Operate	Well Designed Lubrication System Mold Stuck Releasing System
Iron, Aluminum, Copper and Titanium Alloys are Practicable in forging	Longer Stroke Distance Shut Height is adjustable

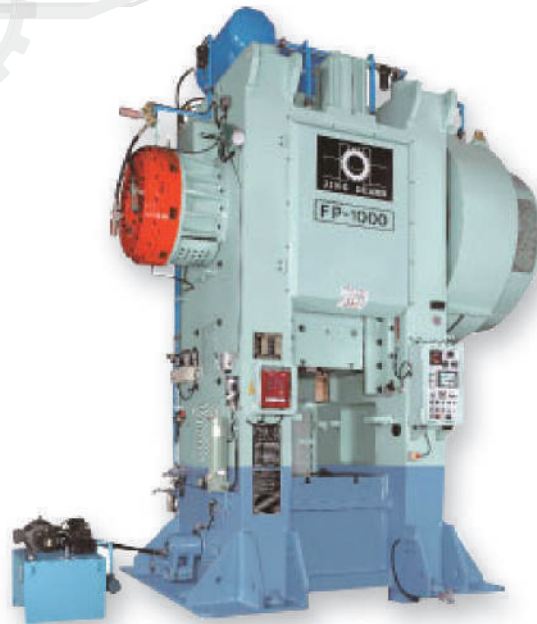

FP-X-Hot-Forging-Presses

MACHINE SPECIFICATIONS

Item / Model	Unit	FP-400	FP-600	FP-800	FP-1000
		(400 TONS)	(600 TONS)	(800 TONS)	(1000 TONS)
Capacity	Tons	400	600	800	1000
Stroke of ram	mm	175	200	250	250
Adjustment of ram	mm	10	10	10	10
Number of stroke	Spm	100	95	85	85
Work number of stroke	Spm	18	18	16	16
Shut height	mm	505	650	650	800
Rated tonnage point	mm	5	5	5	5
(L-R & F-B) Ram dimension	mm	590*650	690*630	800*790	940*850
(L-R & F-B) Table dimension	mm	770*840	880*880	980*1000	1100*1050
(L-R & F-B) Side window	mm	450*450	500*500	600*600	700*650
Main motor	Kw*P	30kw*8p	37kw*8p	45kw*8p	55kw*8p
Ram of adjustment motor	Kw*P	0.4kw*4p	0.4kw*4p	0.75kw*4p	0.75kw*4p
Motor of lubrication	Kw*P	0.1kw*4p	0.1kw*4p	0.1kw*4p	0.1kw*4p
Ejector in the ram	Tons-mm	6Ton-20mm	6Ton-20mm	6Ton-30mm	2.5x3=7.5Ton-30mm
Ejector in the table	Tons-mm	12Ton-40mm	12Ton-40mm	12Ton-40mm	8x3=24Ton-40mm
Ejector hydraulic oil motor	Kw*P	5.5kw*6P	5.5kw*6P	5.5kw*6P	7.5kw*6P
Working number-distance	Number-mm	1	1	1	3-200
Air pressure	kg/cm2	5	5	5	5
Press weight	kg	29,500	40,000	52,000	72,000
(L*W*H) Press dimension	mm	3360*2600*4655	3500*2730*5100	3985*2987*5520	4185*2910*5935

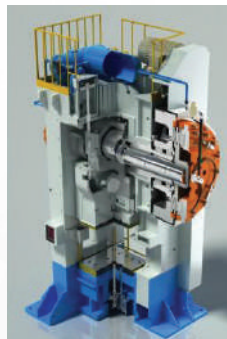
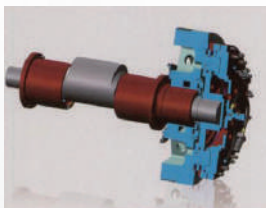
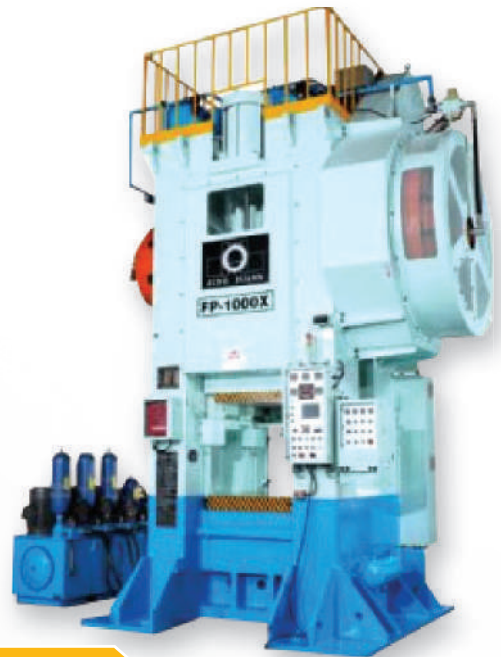

MACHINE SPECIFICATIONS

SPECIFICATION	
Advantages	Design
High Production Efficiency Longer Die Life	FP-X is directly driven by Flywheel, Running speed is fast
High Precision Forging Parts Stable Product Quality	Slider guide rails adopt X-type design
High Safety Standard Ensure the Safety for Operator and Machine	HMI Touch Screen, I/O Monitoring PLC Multi Circuit Loop System, Micro Computer Load Meter
Fulfill the Environmental Protection Standards	New-type Flywheel, Large Gear Suspension Mechanism
Easy to Maintenance Easy to Operate	Well Designed Lubrication System Mold Stuck Releasing System
Iron, Aluminum, Copper and Titanium Alloys are Practicable in forging	Ultra High Rigidity Machine Frame & Semi-hermetic Clutch Mechanism

Item / Model	Unit	FP-600X	FP-800X	FP-1000X	FP-1300X	FP-1600X
Capacity	Tons	600	800	1000	1300	1600
Stroke of ram	mm	200	250	250	280	300
Adjustment of ram	mm	10	10	10	10	10
Number of stroke	Spm	95	85	85	80	65
Work number of stroke	spr	18	18	18	18	18
Shut height	mm	750	850	950	950	1100
Rated tonnage point	mm	6	6	6	6	6
(L-R & F-B) Ram dimension	mm	660*730	770*810	880*1050	1020*1080	1050*1130
(L-R & F-B) Table dimension	mm	800*880	880*1000	1040*1080	1140*1140	1200*1200
(L-R & F-B) Side window	mm	550*550	600*600	700*700	750*700	980*800
Main motor	Kw	37kw*8p	45kw*8p	55kw*8p	75kw*8p	75kw*12p
Ram of adjustment motor	Kw	0.4kw*4p	0.75kw*4p	0.75kw*4p	1.5kw*4p	1.5kw*4p
Motor of lubrication	Kw	0.75kw*4p	0.75kw*4p	0.75kw*4p	0.75kw*4p	0.75kw*4p
Ejector in the ram	Tons-mm	6Ton-30mm	10Ton-30mm	10Ton-30mm	10Ton-40mm	10Ton-40mm
Ejector in the table	Tons-mm	8Ton-50mm	12Ton-50mm	12Ton-50mm	12Ton-50mm	17Ton-50mm
UP-Ejector hydraulic motor	Kw	7.5kw	7.5kw	7.5kw	7.5kw	7.5kw
Down-Ejector hydraulic motor	kw	11kw	11kw	11kw	11kw	11kw
Working number-distance	NO	1	1	1	1	3-200
Air pressure	kg/cm2	5	5	5	5	5
Press weight	kg	46,000	60,000	82,000	100,000	130,000
(L*W*H) Press dimension	mm	3300*2790*5280	3630*3010*5810	3840*3225*6145	4100*3450*6675	4320*3505*8100

Cutting Machine / Punching Machine

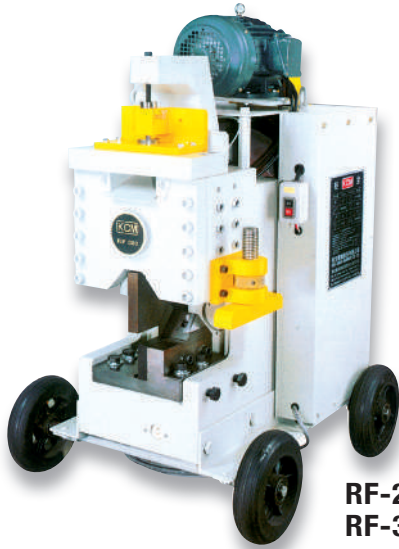

RF-260
RF-320

WORKING CAPACITY

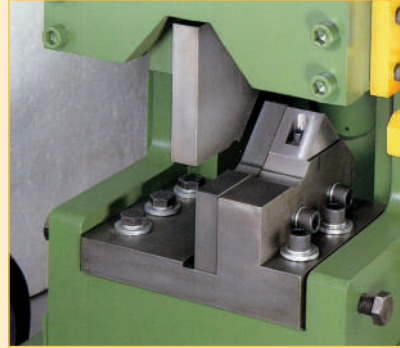

① Square cut RF260 • 19 □ RF320 • 25 □	② Angle cut RF260 • 6t×50×50 RF320 • 9t×75×75
③ Bar cut RF260 • 25 ∅ RF320 • 32 ∅	④ Flat cut RF260 • 10t×65 RF320 • 12t×75

DESCRIPTION

DESCRIPTION	RF-260	RF-320
Increasing Pressure	30ton	50ton
Stroke	50m/m	40m/m
Motor	1,5kw x 1,5P	2.2kw x 3P
Size	H W L 660x580x1,050m/m	H W L 700x710x1,300m/m
Weight	500Kg	950Kg

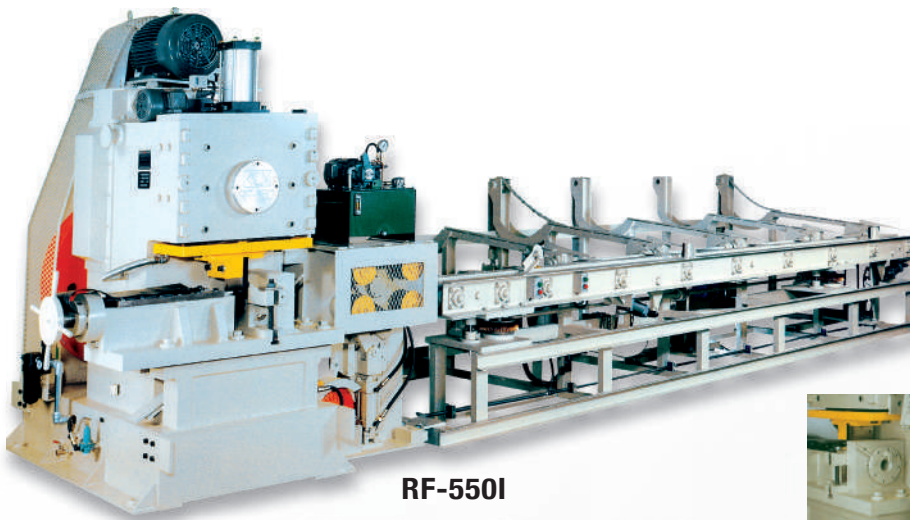

RF-550I



MACHINE SPECIFICATIONS

MODEL	RF-320C		RF-320I		RF-380I		RF-450I		RF-550I		RF-600I		RF-750I		RF-1000I																					
Pressure (T)	50		50		90		120		160		200		300		400																					
Stroke	SPM		70		60		50		50		40		40		40																					
	Long (mm)		40		40		60		65		75		85		100																					
Motor	Body		3HP (4P)		3HP (4P)		10HP (6P)		15HP (6P)		20HP (6P)		25HP (6P)		40HP (6P)																					
	Oil supply										0.4(4P)		0.4(4P)		0.4(4P)																					
Feeding speed (m/min)	45		45		45		45		40		40		40		40																					
Speed Reducer (1/20 kw)	2HP		2HP		2HP		2HP		2HP		3HP		3HP		3HP																					
Main Air Pressure (Kg)	4		5-6		5-6		5-6		6-7		6-7		6-7		6-7																					
Body	Long x		800x700x1100		1100x850x1600		1300x1000x1950		1500x1000x2000		1800x1300x2200		1900x1380x2350		2000x1560x2400		2600x1700x2500																			
	Feeding Pack		Wide x High (m/m)		6500x1520x1050		6500x1520x1050		6500x2000x1150		6500x2200x1250		6500x2200x1250		6500x2200x1250		6500x2200x1250																			
Body	Feeding Pack		1000		2000		5000		6000		8500		14000		20000		28000																			
	Feeding Pack		Weight (Kg)		2500		2500		2500		3000		3000		3500		3500																			
Feeding Pack (∅)	Quality	Anti Tension	Big	Small	Big	Small	Big	Small	Big	Small	Big	Small	Big	Small	Big	Small	Big	Small																		
																			S 45C	32	10	32	10	38	15	45	15	55	20	60	20	75	30	100	30	
																			S 58C	70	28	10	28	10	40	15	45	15	50	20	55	20	70	30	90	30
																			SCM415	90	24	10	24	10	30	15	38	15	45	20	50	20	65	30	85	30

NC Trunmulti-Spindle Combination Machining Centers

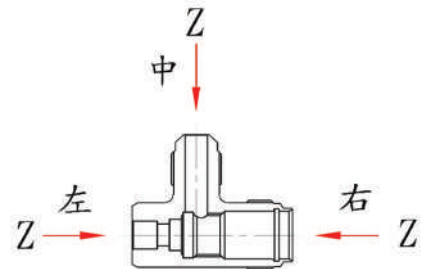
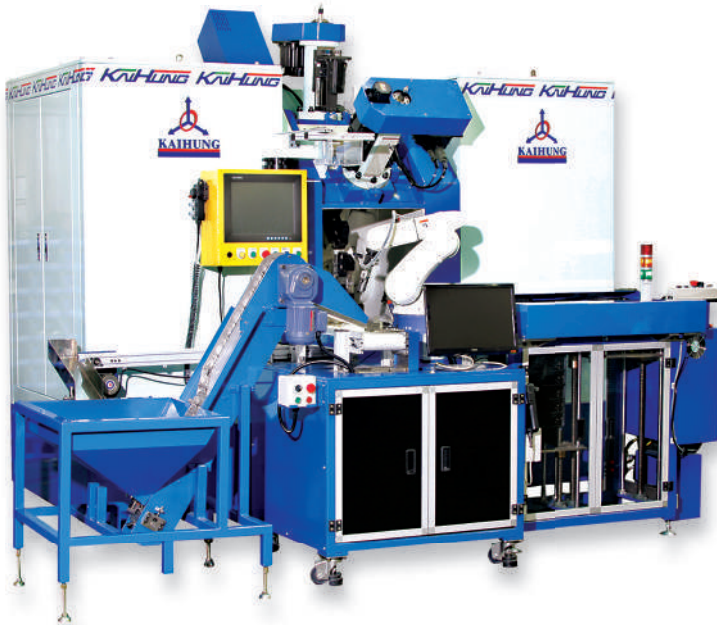

Designed for simultaneously tri-directional processing with center hole, 3DS-NC multi-spindle mill-type machining center handling boring, tapping, groovings ect. of asymmetrical casting, forgings, bars/roods tri-directionally (0°,90°,180°) without secondary clamping to achieve high concentricity, asymmetry, verticality and parallelism, with CPK value exceeding 1.33.

MACHINE SPECIFICATIONS

SPEC/MODEL	UNIT	KH-D-80	KH-D-120	KH-D-160	KH-D-200
General capacity					
Machining direction	0°, 90°, 180°	D/2D/3D	D/2D/3D	D/2D/3D	D/2D/3D
The number of spindles	Branch	2-20	2-18	2-18	2-16
Dial					
Turntable equal parts	Station	4~12	4~12	4~12	4~12
Rotary drive		Servo motor	Servo motor	Servo motor	Servo motor
Dial time	S	1.7	1.7~2.0	2.0~3.0	2.0~3.5
Fixture	Hydraulic	Sync jaws			
		One-way clamp			
		Three-jaw chuck			
		Homemade chuck			
SPINDLE					
Shaft tube diameter	mm	Ø 80	Ø 120	Ø 150	Ø 200
Z spindle travel	mm	150	150	180	220
Spindle speed	rpm	4000	4000	3000	2000
Cutting feed rate	m/min	1-10	1-10	1-10	1-10
Shank size	type	NT:30	NT:40	NT:40	NT:50
0°, 180° Slide stroke		Do special design according to product			
X-axis travel	mm	50	100	150	175
Y-axis travel	mm	50	150	175	200
Stages fast feed	m/min	24	18	15	12
90° Slide stroke		Do special design according to product			
X-axis slide stroke	mm	75	125	150	175
Y-axis slide stroke	mm	75	150	250	250
Stages fast feed	m/min	24	18	15	12
Electronic control					
(X,Y,Z) Servo motor	Taiwan-made	Delta	Delta	Delta	Delta
Controller	Taiwan-made	P.C Base	P.C Base	P.C Base	P.C Base
Other					
Cutting fluid tank capacity (ℓ)		40	60	60	60
Electrical control box air conditioning ther mostat (C°)		35-50	35-50	35-50	35-50
SELECT WITH					
Controller	European system	PC.Base	PC.Base	PC.Base	PC.Base
	Editor	G.M Code	G.M Code	G.M Code	G.M Code
	Mode	Coordinate	Coordinate	Coordinate	Coordinate
(X,Y,Z) Servo motor	European system	Lenze	Lenze	Lenze	Lenze
	Japanese	Mitsubishi	Mitsubishi	Mitsubishi	Mitsubishi
		Yaskawa	Yaskawa	Yaskawa	Yaskawa
Stabilizer	KVA	Based on actual KVA			
Quick tool change	HSK System	o	o	o	o
Shaped punching		x	o	o	o
Broach		x	o	o	o
Tool within the flushing		o	o	o	o

CNC Multi-Spindle Combination Machining Center

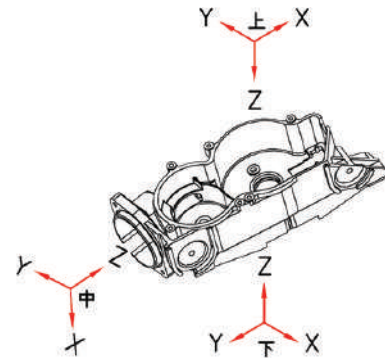

3D Multi-spindle machining center for high-efficiency production enables flexible programming to achieve 5~10 time the output of one central machining center and NC lathe while occupying less space, requiring fewer operators and lower maintenance cost, handling simultaneously tri-directional (0°,90°,180°) processing of asymmetrical castings, forgings, bars/rods without secondary clamping to achieve high concentricity, symmetry, verticality parallelism, with CPK value exceeding 1.33.



Logical multi-spindle alignment



Servo-slide simultaneously tri-directional (upper, middle and lower) processing

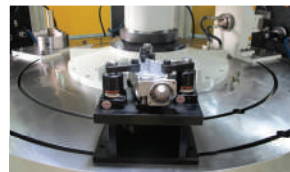

Chuck faceplate (1,500mm dia. & 0.02 planar tolerance) for exchange, clamping and quick positioning.



High-strength, high-precision synchronizing chuck for minimal blank OD change and symmetry of output.

PROCCSSING EXAMPLES



4" to 8" Ling hot water pipes



20mm~15mm water meter head



Gas solenoid valve



Faucet



Hot water trachea joints



Hot All kinds of copper fittings



Electronic connectors



Lock



Hot water Aluminum forgings, aluminum extrusion, Auto part, bicyclejoints

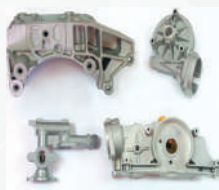

Aluminum and zinc castings, motor housings, auto parts



Aluminum and zinc castings, power tools, home appliance parts



Pneumatic solenoid valve Part

LINEAR SCALE

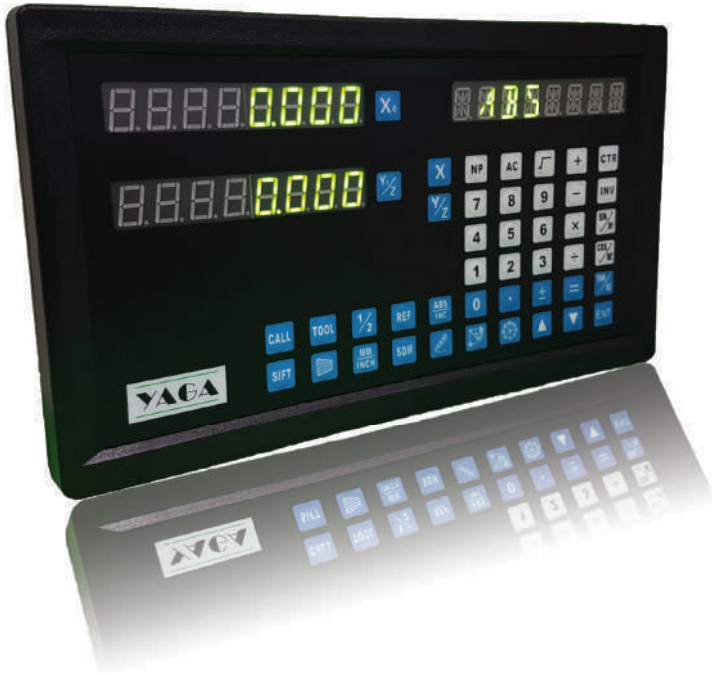

MILLING AND BORING MACHINES

RESOLUTION

0.5 - 1 - 2 - 5 - 10 micron

AXES

2e: X - Z

2e: X - Y - Z

DRO dedicated to milling or boring machine, with a simple and clean structure, it has a number of useful features to simplify the operator's job. It also provides a practical integrated calculator that interacts with the displayed coordinates.

Robust structure in steel and plastic that protects against intrusion of foreign bodies or liquid splash. It is furnished as standard with a simple support bracket to secure it to the machine.

OPTICAL SCALES

DIMENSION

1.250 ÷ 3.000 mm

FUNCTIONS AND FEATURES

The GT and GR series have been designed to achieve quality and reliability at competitive prices.

They can be installed on both machine tools and measurement Instruments, and are available with TTL (for DROs) and EIA 422 A (for CNC) output signals.

Travels range from 1.250 mm up to 3.000 mm with resolution of 5 micron and 1 micron.

The supply includes everything is necessary for a quick and easy installation (aluminium protection, brackets, screws etc.) All scales are laser inspected.



CONNETTORE MASCHIO MALE CONNECTOR AUSSENGEWINDE VERBINDER

PIN	TTL		422A	
	Segnale Signal	Cablaggio Cable Kabel	Segnale Signal	Cablaggio Cable Kabel
1			A-	●
2	DV	●	DV	○
3			B-	●
4	Gnd	↓	Gnd	↓
5			R-	●
6	A	●	A+	●
7	+5V	●	5V	●
8	B	●	B+	●
9	R	●	R+	●

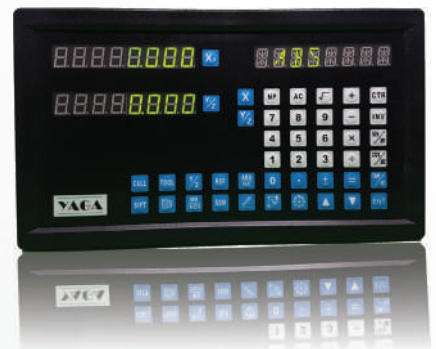

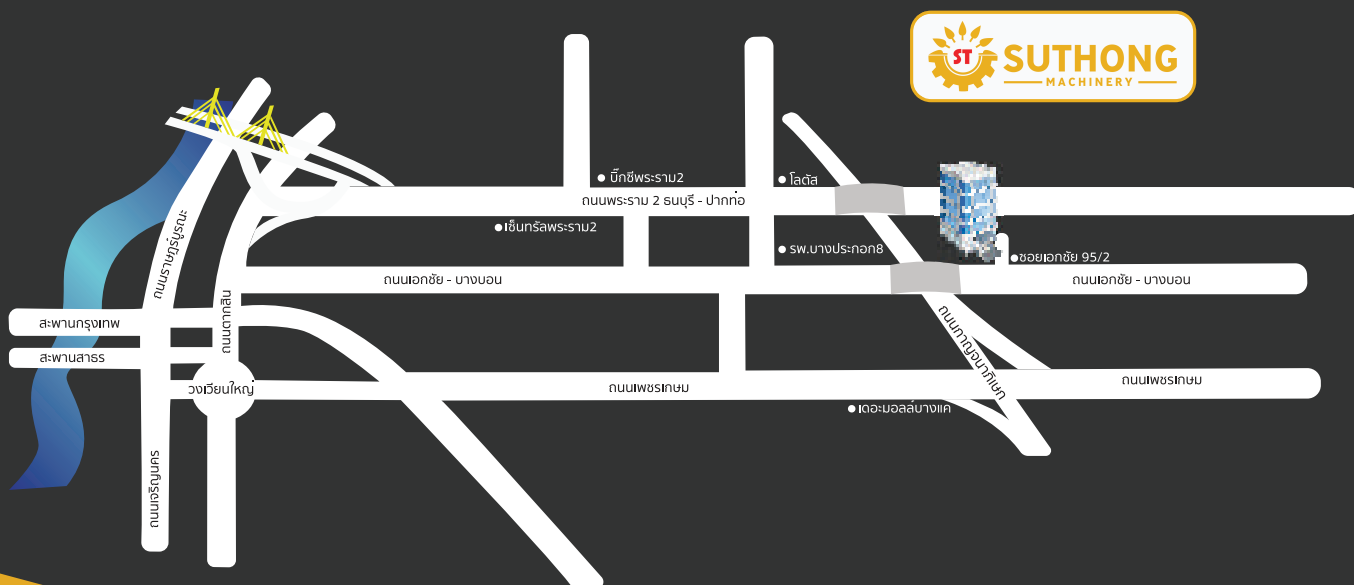

บริษัท สุธอง แมชชีนเอนอรี่ จำกัด
SUTHONG MACHINERY CO.,LTD.

เลขที่ 7/11 ซอย เอกชัย 95/2 แขวงบางบอนใต้ เขตบางบอน กรุงเทพมหานคร 10150
 No. 7/11 Ekkachai 95/2 Alley, Bang Bon Tai, Bang Bon, Bangkok 10150
 Hotline : 064-992-8966 E-mail : customer@suthong.co.th www.suthong.co.th

