

PHOEBUS DABEM®

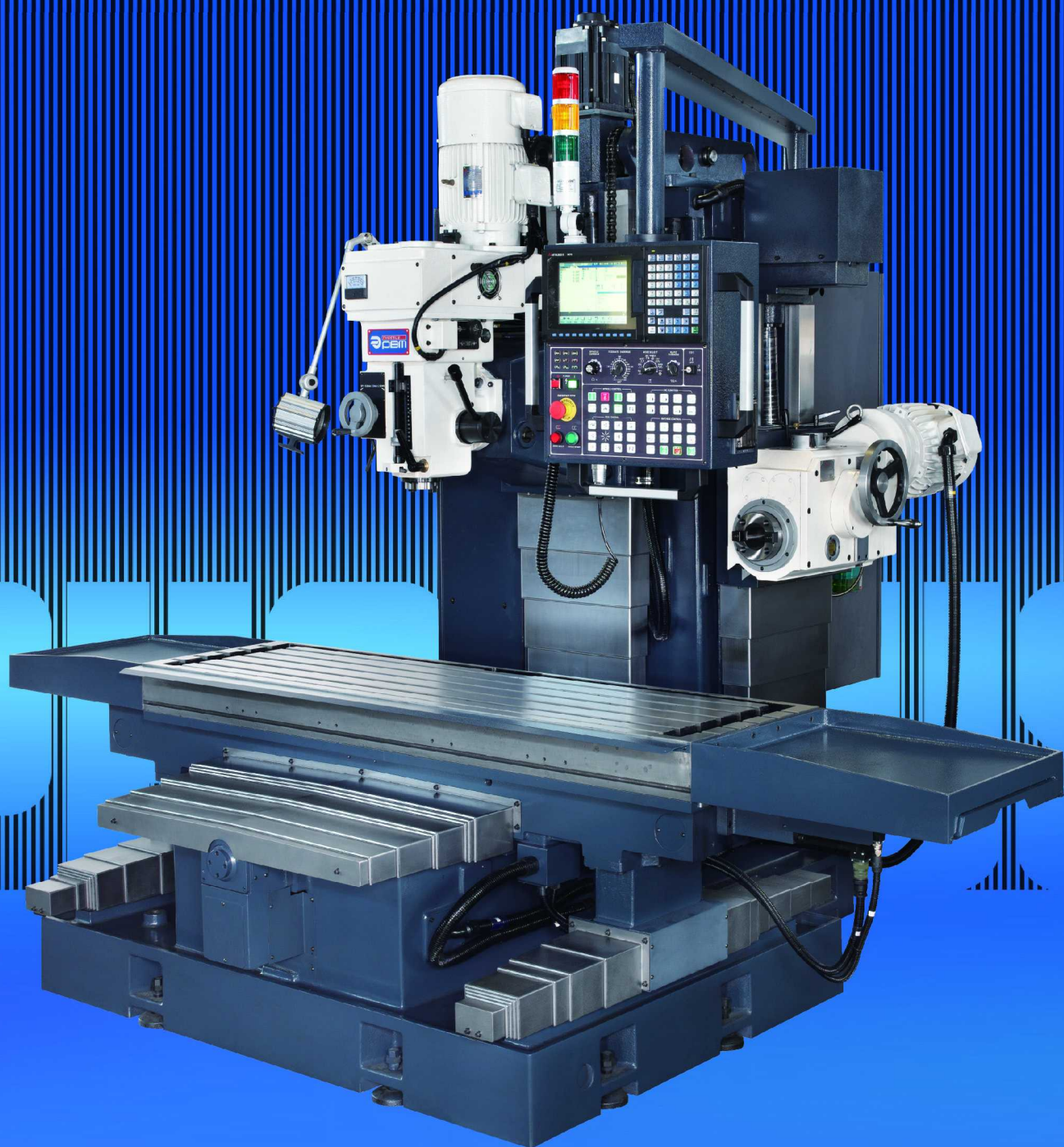

PBM-VST1500 CNC

BED TYPE CNC MILL

PBM-VST1200 CNC

TURRET TYPE INVERTER

VARI. SPEED HEAD

SPINDLE TAPER N.S.T.40

CNC CONTROLLER



SPECIFICATIONS

UNIT : MM 50HZ

ITEMS		VST1500 CNC	VST1200 CNC
TABLE	SIZE (L x W)	1800 x 520	1470 x 350
	T SLOT (W x NO. x PITCH)	18 x 5 x 80	18 x 3 x 100
	MAX. LOAD TABLE (KGS)	800	600
TRAVEL	X. Y. Z. H AXES	1500 x 630 x 600 x 550	1200 x 520 x 600
RAPID	X. Y. Z. H AXES	8000	8000
FEED	X. Y. Z. H AXES	4000	4000
SLIDY WAY	LONG. / CROSS	DOUBLE V TYPE	
	VERTICAL & HORIZONTAL	SQUARE TYPE	
VERTICAL SPINDLE	SPINDLE NOSE	N.S.T 40	
	STEPS	INVERTER VARIABLE	
	SPINDLE SPEED RPM	60-3600	
	SWIVELLING ANGLE	45° (R & L)	
	QUILL TRAVEL	140	
	QUILL FEEDS / REV	0.035 / 0.07 / 0.14	
	SPINDLE NOSE TO TABLE	100 - 700	
	SPINDLE CENTER TO COLUMN	660	520
HORIZONTAL SPINDLE	SPINDLE NOSE	N.S.T 50	—
	STEPS	6	—
	SPINDLE SPEED RPM	100 - 590	—
	VERTICAL TRAVEL	550	—
	CROSS TRAVEL MANUAL	300	—
	SPINDLE NOSE TO COLUMN	-150 TO +150	—
	SPINDLE CENTER TO TABLE	0 - 550	—
	DISTANCE BETWEEN TWO SPINDLE	690	—
MOTOR	VERTICAL SPINDLE	5 HP - 4P	
	HORIZONTAL SPINDLE	7.5 HP - 4P	—
	FEED (X. Y. Z. H)	AC2.2 x 2.2 x 3.5 x 3.5 Kw	AC1 x 1 x 1 Kw
	COOLANT PUMP	1/8 HP - 2P	
SIZE	MACHINE (L x W x H)	3050 x 2200 x 2590	2334 x 2005 x 2490
	NET WEIGHT (KGS)	6100	4000
* SPECIFICATIONS MAY BE CHANGED OR IMPROVED WITHOUT NOTICE.			

BED TYPE VERT. & HORI. MILL

PBM-VST1500

TURRET TYPE INVERTER
VARI. SPEED HEAD
SPINDLE TAPER N.S.T.40

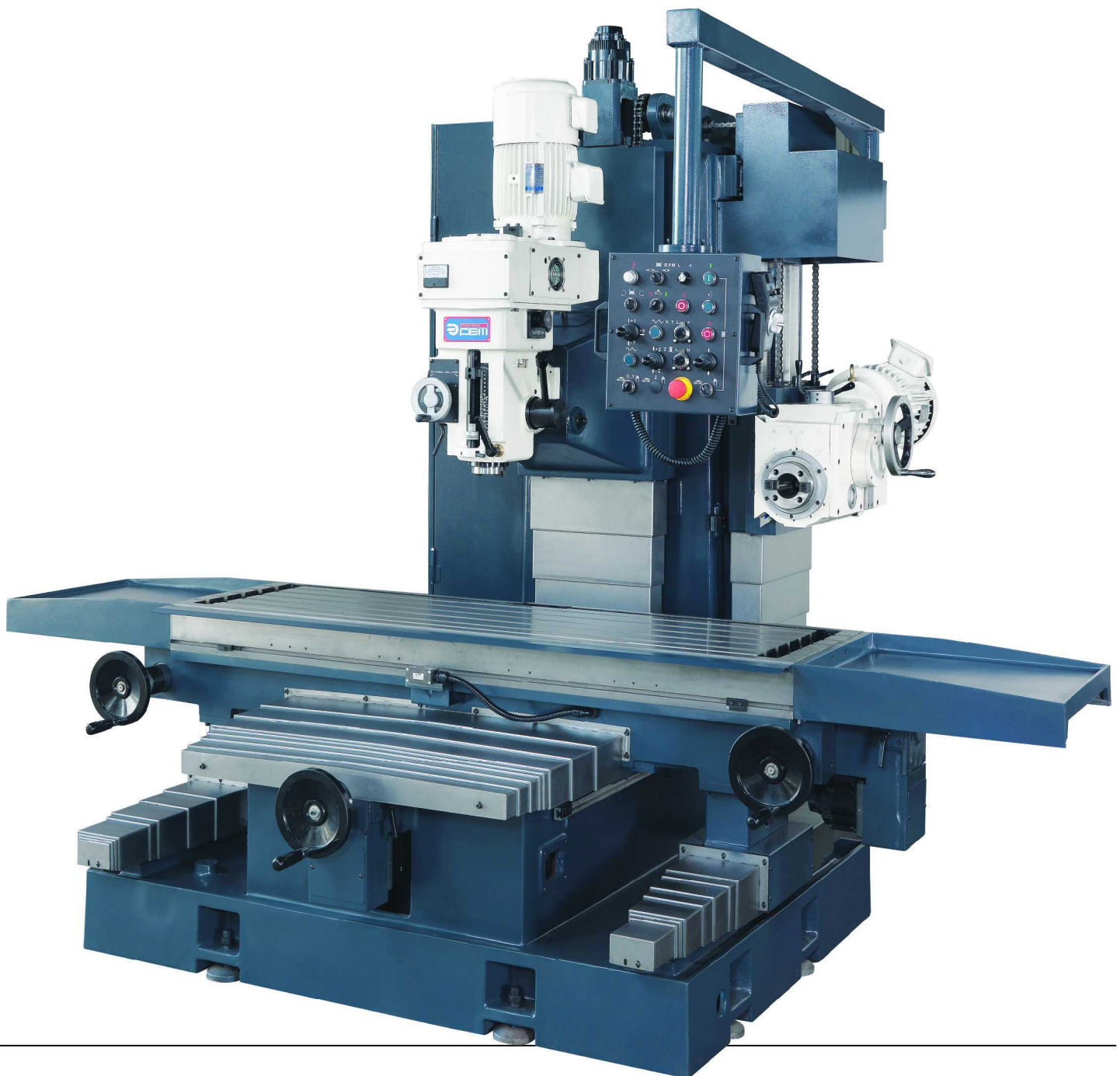

BED TYPE VERT. & HORI. MILL

PBM-GST1500

**VERTICAL & HORIZONTAL
GEAR TYPE SOLID HEAD
SPINDLE TAPER N.S.T.50**



BED TYPE VERTICAL MILL

PBM-VST1200

TURRET TYPE INVERTER

VARI. SPEED HEAD

SPINDLE TAPER N.S.T.40



BED TYPE VERTICAL MILL

PBM-ST1200

**HEAVY DUTY INVERTER
VARI. SPEED HEAD
60-1500RPM, 15HP
SPINDLE TAPER N.S.T.50**



FEATURES

- MODEL 1500, 1200 SERIES WITH FINEST DOUBLE V TYPE SLIDE WAY ON X,Y AXES. ITS STABLE MOVEMENT PROVIDE BETTER STABILITY TO MAINTAIN LONG TERM PRECISION AND HIGHLY PRECISE FEEDING.
- MODEL 1500 SERIES WITH VERY WIDE SADDLE WITH 2000 MM WIDTH AND AUXILIARY SLIDE WAYS KEEP TABLE STABLE AND ACCURACY MOVEMENT IN ALL DIRECTION, TO PREVENT ANY DEFORMATION AND ALLOWANCE OCCURRED FROM MACHINING PERFORMANCE.

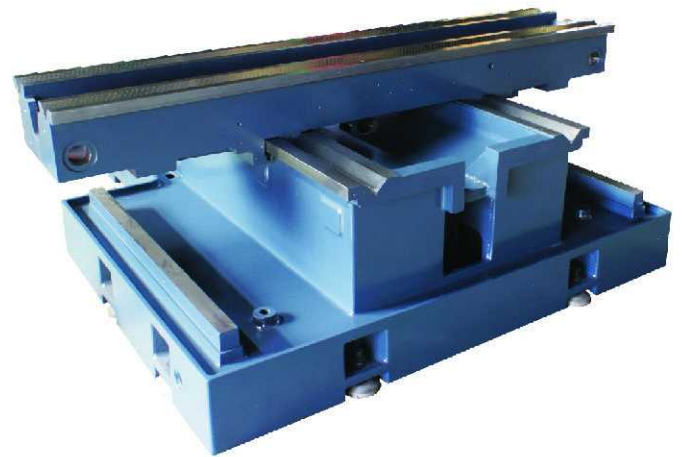

- X · Y · Z · H AXES FEED ARE EQUIPPED WITH HIGH PRECISION DOUBLE NUT BALL SCREW. IT'S FULLY SUPPORTED MOVEMENT MAINTAINS LONG WEAR RESISTANCE AND HIGHLY PRECISE FEEDING.



- THE VST1500, 1200 VERTICAL HEAD EQUIPPED WITH THE LUBRICATION PUMP. IT CAN BE LUBRICATING AND COOLING THE GEAR INSIDE OF THE HEAD. TO PREVENT NOSIY AND DEFORMATION OCCURRED FROM OVER HEATING.



- THE MODEL GST1500 SERIES WITH BOX-FRAME CONSTRUCTION BASE AND AUXILIARY SLIDE WAYS TO ENSURE IT'S EXCELLENT RIGIDITY SUITABLE FOR HIGH PRECISION AND HEAVY DUTY CUTTING OF A LONG SERVICE LIFE.

DIMENSION

PBM-GST1500

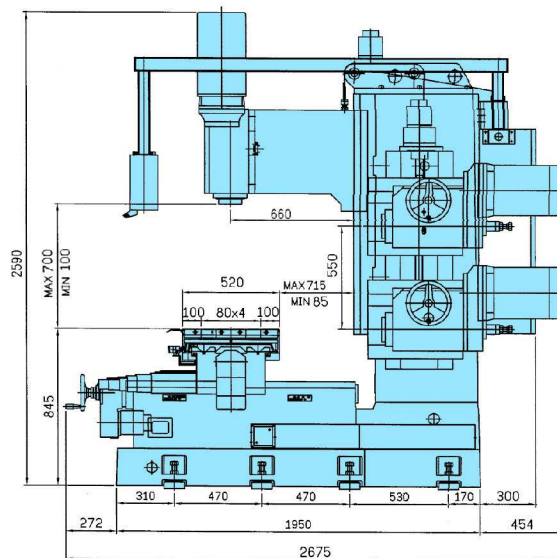
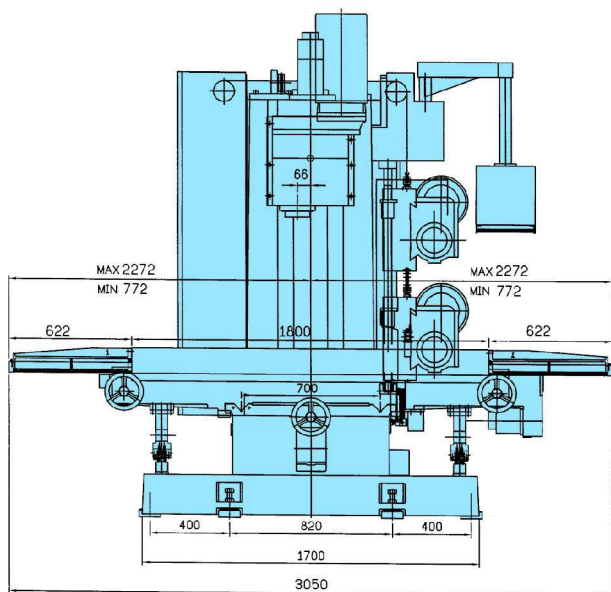

PBM-VST1200

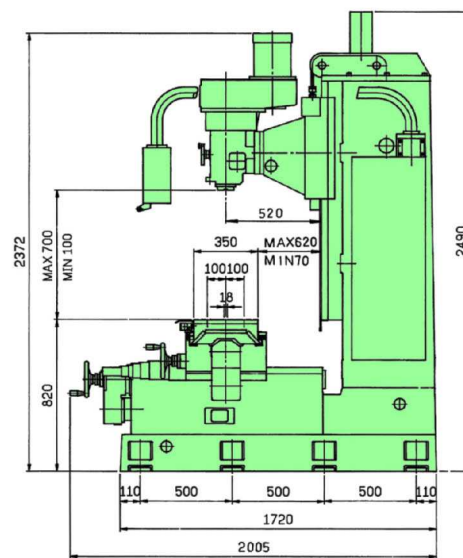
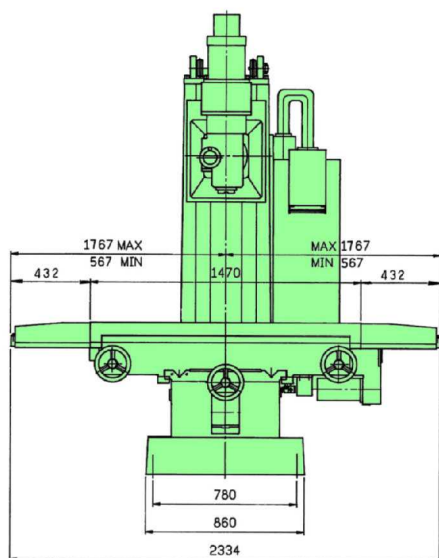

STANDARD ACCESSORIES

1. COOLANT EQUIPMENT
2. X, Y, Z, H, AXES BALL SCREW
3. X, Y, Z, H, AC SERVO MOTOR
4. Z, H, AXES MPG SYSTEM
5. Y, Z, H, TELESCOPIC COVER
6. X, Y, Z, H, SLIDE WAYS AUTO LUB. PUMP

SPECIFICATIONS

UNIT : MM 50HZ

ITEMS		GST1500	VST1500	VST1200
TABLE	SIZE (L x W)	1800 x 520		1470 x 350
	T SLOT (W x NO. x PITCH)	18 x 5 x 80		18 x 3 x 100
TRAVEL	TRAVEL (X • Y • Z • H)	1500 x 630 x 600 x 550		1200 x 520 x 600
FEED	FEED (X • Y • Z • H)	30-3000 / MIN		
SLIDY WAY	LONG. / CROSS	DOUBLE V TYPE		
	VERTICAL & HORIZONTAL	SQUARE TYPE		
VERTICAL SPINDLE	SPINDLE NOSE	N.S.T 50	N.S.T 40	
	STEPS	6	INVERTER VARIABLE	
	SPINDLE SPEED RPM	92 - 593	60-3600	
	SWIVELLING ANGLE	FIXED	45° (R & L)	
	QUILL TRAVEL	—	140	
	QUILL FEEDS / REV	—	0.035 / 0.007 / 0.14	
	SPINDLE NOSE TO TABLE	65 - 665	100 - 700	
	SPINDLE CENTER TO COLUMN	660	520	
HORIZONTAL SPINDLE	SPINDLE NOSE	N.S.T 50	—	
	STEPS	6	—	
	SPINDLE SPEED RPM	100 - 590	—	
	VERTICAL TRAVEL	550	—	
	VERTICAL FEED	30 - 3000 / MIN	—	
	CROSS TRAVEL MANUAL	300	—	
	SPINDLE NOSE TO COLUMN	-150 TO +150	—	
	SPINDLE CENTER TO TABLE	0 - 550	—	
	DISTANCE BETWEEN TWO SPINDLE	690	—	
MOTOR	VERTICAL SPINDLE	10 HP - 4P	5 HP - 4P	5 HP - 4P
	HORIZONTAL SPINDLE	7.5 HP - 4P		—
	FEED (X • Y • Z • H)	AC SERVO 850W		
	COOLANT PUMP	1/8 HP - 2P		
SIZE	MACHINE (L x W x H)	3050 x 2675 x 2590		2334 x 2005 x 2490
	NET WEIGHT (KGS)	6600	6400	4000
* SPECIFICATIONS MAY BE CHANGED OR IMPROVED WITHOUT NOTICE.				

BED TYPE VERTICAL MILL

PBM-ST300

**HEAVY DUTY INVERTER
VARI. SPEED HEAD
SPINDLE TAPER N.T.40**

FUNCTIONS:

1. X • Y • Z AXES SERVO MOTOR
2. X • Y • Z AXES BALL SCREW



BED TYPE VERTICAL MILL

PBM-VST300

TURRET INVERTER
VARI. SPEED HEAD
SPINDLE TAPER
N.S.T.40

FUNCTIONS:

1. LONGITUDINAL POWER FEED AND RAPID TRAVERSE GEAR BOX TYPE
2. CROSS MANUAL MOVEMENT
3. VERTICAL RAPID TRAVERSE
4. 3 AXES LEAD SCREW MOVEMENT

OPTIONAL FUNCTIONS

SELECTED ITEM 1. OR 2.

1. X, Y, AXES BALL SCREW WITH INVERTER MOVEMENT, STEPLESS SPEED RANGE FROM 50-2200 MM/MIN
2. 3 AXES BALL SCREW WITH 3 AXES AC SERVO MOTOR DRIVING SYSTEM



WIDE SELECTION ON DIFFERENT TURRET HEAD ON MODEL PBM-VST300 & PBM-5VSB



PBM-VST300A

MOTOR : 5HP-2P/4P
 QUILL DIA : 110mm
 AUTO TRAV : 140mm
 16 SPEED 62-3000 RPM



PBM-VST300B

MOTOR : 5HP-4P
 QUILL DIA : 105mm
 AUTO TRAV : 127mm
 10 SPEED 60-3000 RPM

DIMENSIONS

PBM-VST300

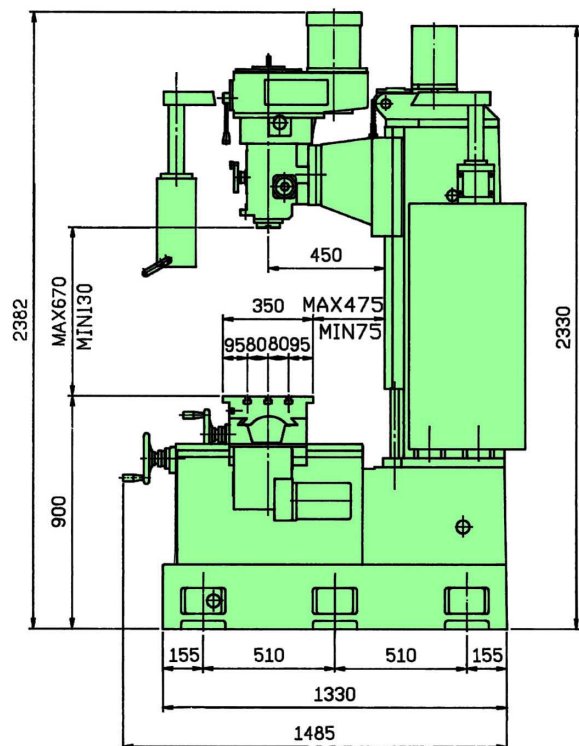
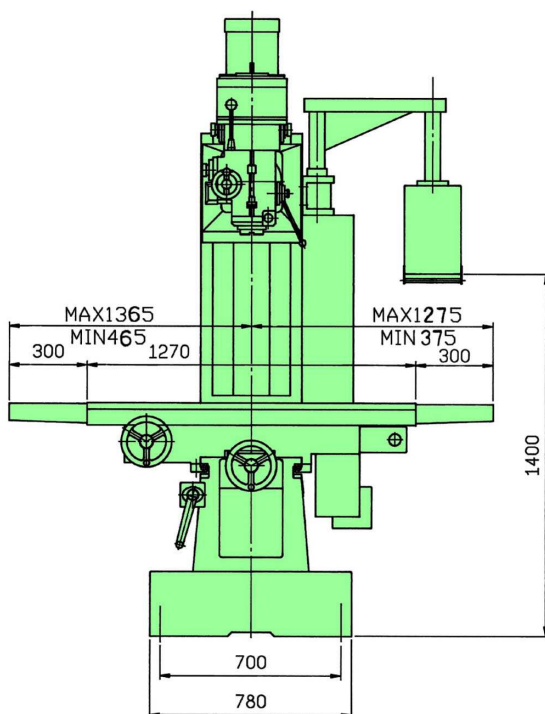

BED TYPE VERTICAL MILL

PBM-5VSB

TURRET TYPE VARI. SPEED HEAD SPINDLE TAPER N.S.T.40

FUNCTIONS

1. LONG. & CROSS MANUAL MOVEMENT
2. VERTICAL RAPID TRAVERSE
3. COOLANT EQUIPMENT

OPTIONAL FUNCTIONS

1. X,Y POWER FEED UNIT
2. AIR POWER DRAW BAR



SPECIFICATIONS

UNIT : MM 50HZ

ITEMS		PBM-VST300	PBM-ST300	PBM-5VSB
TABLE	SIZE (L x W)	1270 x 370 (1470 x 370 OPT.)		1270 x 254
	T SLOT (W x NO. x PITCH)	16 x 3 x 80		16 x 3 x 63
TRAVEL	X x Y x Z - MANUAL	930 x 430 x 550		775 x 430 x 550
	X x Y x Z - AUTO	920 x 410 x 540		700 x 410 x 540
FEED	LONG. / MIN	18-640 (12 STEPS)	30 - 3000 VARI.	—
	LONG. RAPID TRAVERSE / MIN	2083	—	—
	CROSS / MIN	—	30 - 3000 VARI.	—
	VERTICAL / MIN	565 RAPID	30 - 2200 VARI.	565 RAPID
SPINDLE	SPINDLE NOSE	N.S.T 40		N.S.T 40
	STEPS	INVERTER VARIABLE		VARIABLE
	SPINDLE SPEED RPM	60 - 3600	60-1500	66 - 3165
	SWIVELLING ANGLE	45° (R&L)	FIXED	45° (R&L)
	QUILL TRAVEL	140	—	127
	QUILL FEEDS / REV	0.035/0.07/0.14	—	0.04/0.08/0.15
	SPINDLE NOSE TO TABLE	130 - 670		155 - 695
SPINDLE CENTER TO COLUMN	450			
MOTOR	VERTICAL SPINDLE	5 HP - 4P INVERTER	5HP - 6P INVERTER	5 HP - 4P
	FEED LONG.	3/4 HP - 4P	SERVO 750W	—
	FEED CROSS	—	SERVO 750W	—
	FEED VERTICAL	1HP - 2P/4P	SERVO 850W	1/2 HP - 4P - 1/5
	COOLANT PUMP	1/8 HP - 2P		
SIZE	MACHINE (L x W x H)	1870 x 1485 x 2330		
	NET WEIGHT (KGS)	2550	2600	2300
* SPECIFICATIONS MAY BE CHANGED OR IMPROVED WITHOUT NOTICE.				